

OY, OCY Series



FLOW REGULATOR MODULAR VALVE

- 50~200ℓ/min (13.2~52.9 gpm)
210, 250 kgf/cm² (3000, 3571 psi)

Features

1. This valve is used for actuator speed control.
2. Various models are available for A/B-port flow control, A or B port flow control, P or T port flow control.
3. The maximum operating pressure of this valve is 210 kgf/cm² (3000 psi), 250 kgf/cm² (3571 psi).

Specification

Model	Valve size	Max. Operating Pressure kgf/cm ² (psi)	Max Flow ℓ/min (gpm)	Cracking Pressure of Check Valve kgf/cm ² (psi)	Weight kgf (lb)
OY-G01-T-(E)20	1/8	250 (3571)	50 (13.2)	—	0.99(2.2)
OCY-G01-P-(E)20				0.4 (5.7)	1.0 (2.2)
OCY-G01-W-X-(E)20 A B				0.8 (11.4)	1.3 (2.9)
					1.2 (2.6)
OCY-G01-W-Y-(E)20 A B				0.8 (11.4)	1.3 (2.9)
		1.2 (2.6)			
OCY-G03-P-J50	3/8	250 (3571)	100 (26.5)	0.4 (5.7)	2.9 (6.4)
OCY-G03-W-X-J50 A B				1.0 (14.3)	3.1 (6.8)
					3.0 (6.6)
OCY-G03-W-Y-J50 A B	1.0 (14.3)	3.1 (6.8)			
		3.0 (6.6)			
OCY-G06-P-10	3/4	210 (3000)	200 (52.9)	0.4 (5.7)	10.0 (22)
OCY-G06-W-X-11 A B				1.5 (21)	9.7 (21)
					9.5 (21)
OCY-G06-W-Y-11 A B	1.5 (21)	9.7 (21)			
		9.5 (21)			

Model Code

OCY-G03-W-Y-(K)-J50

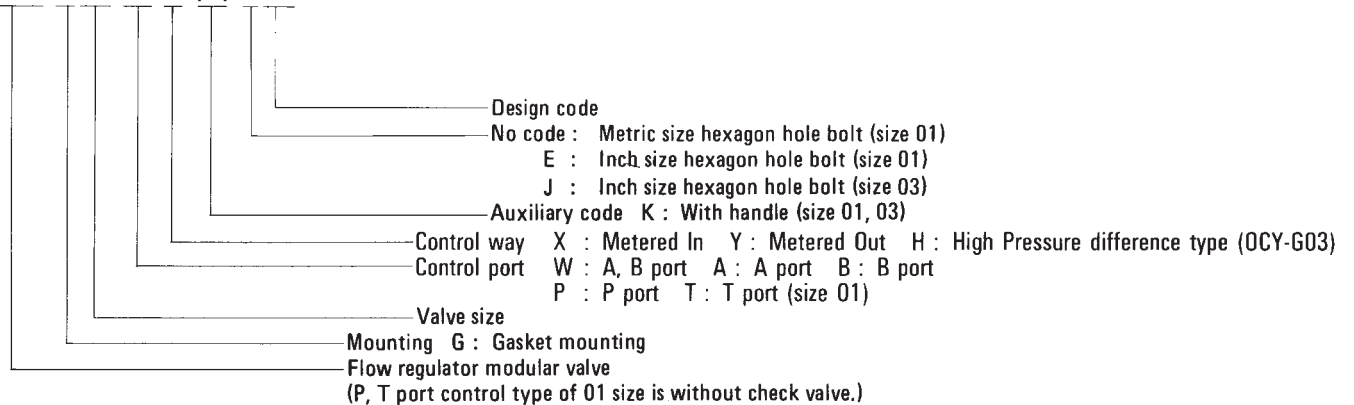

OY, OCY Series

Installation Dimensions mm (inch)

OCY-G01-W-X_Y-(E)20

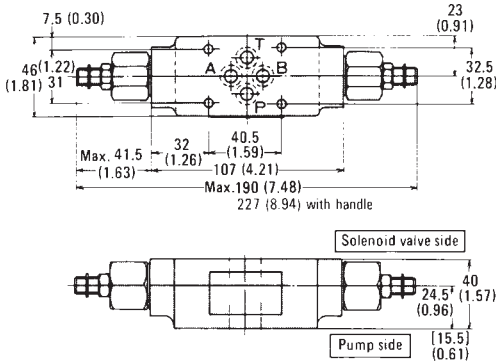

() dimensions for the OCY-G01-W-X-(E)20.

OCY-G01-B-X_Y-(E)20

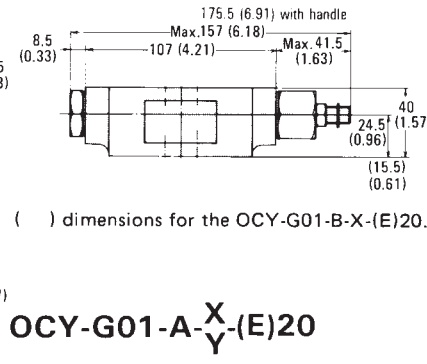

() dimensions for the OCY-G01-B-X-(E)20.

OCY-G01-A-X_Y-(E)20

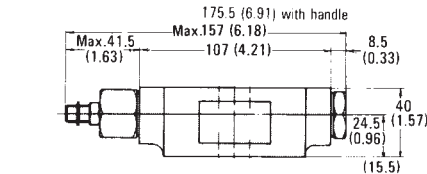

() dimensions for the OCY-G01-A-X-(E)20.

OCY-G01-P-(E)20

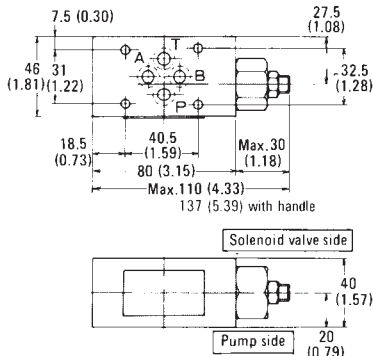

OCY-G03-P-J50

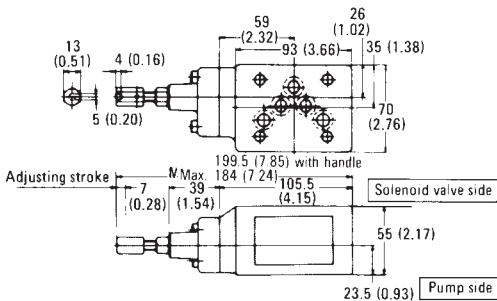

OCY-G06-P-10

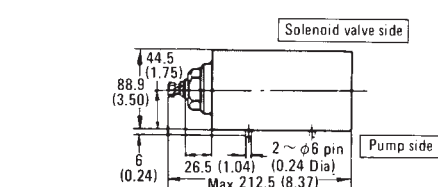

Note) Clockwise rotation of adjusting screw (bolt) decreases flow. Counter-clockwise rotation increases flow.

OY-G01-T-(E)20

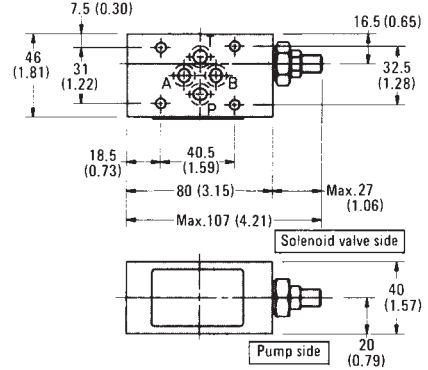

OCY-G03-A-X_Y-J50

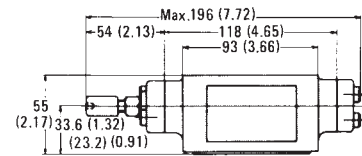

OCY-G03-B-X_Y-J50

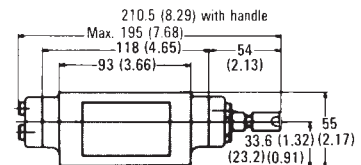

() dimensions for the OCY-G03-X-J50.

OCY-G03-W-X_Y-J50

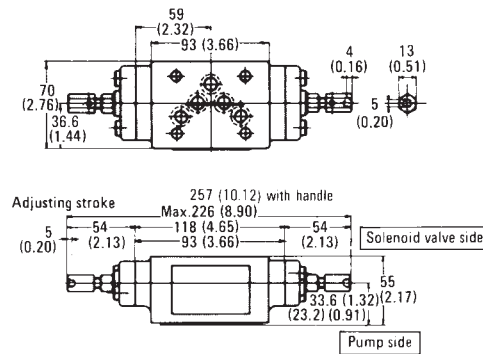

OCY-G06-W-X_Y-11

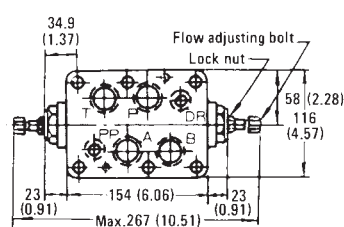

OCY-G06-A-X_Y-11

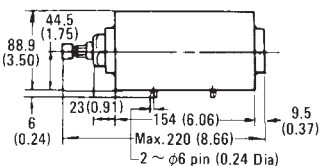

OCY-G06-B-X_Y-11

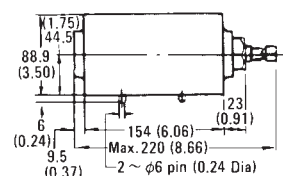

Modular Valves

OY, OCY Series

Performance Curve

Pressure Drop Characteristics

OY-G01-T-(E)20

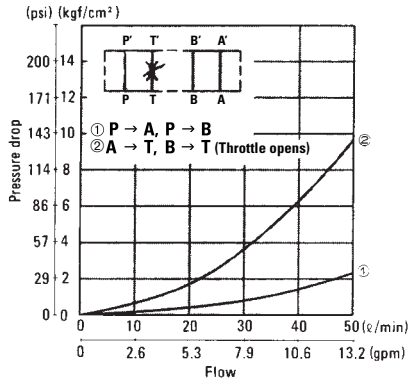

OCY-G01-P-(E)20

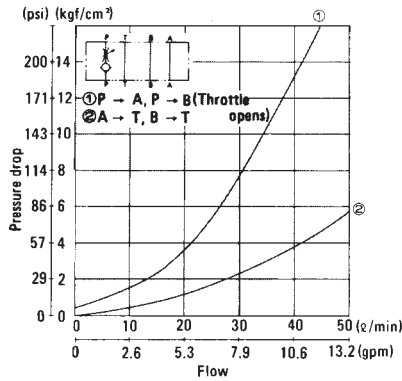

OCY-G01-W-Y-(E)20
(OCY-G01-W-X-(E)20)

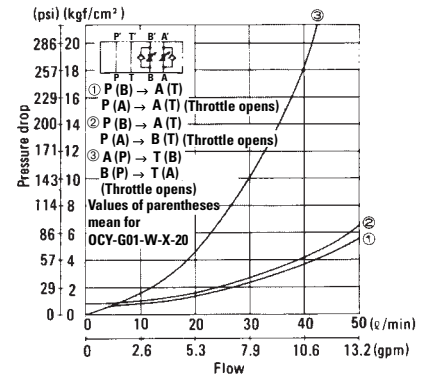

Viscosity of hydraulic fluid 32cSt.

OCY-G03-P-J50

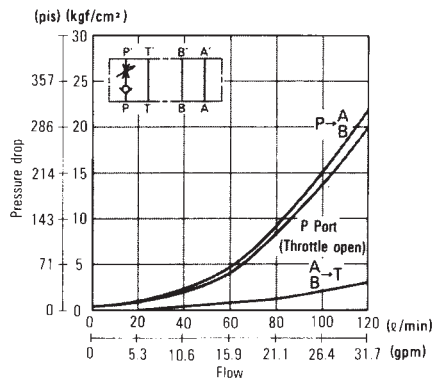

OCY-G03-W-Y-J50
(OCY-G03-W-X-J50)

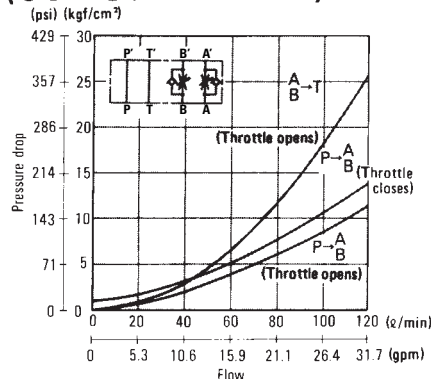

OCY-G06-P-10

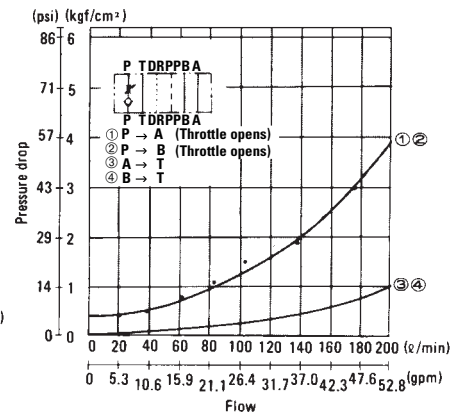

OCY-G06-W-Y-11
(OCY-G06-W-X-11)

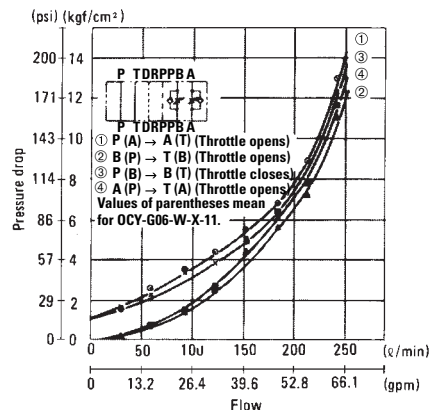

OY, OCY Series

Stroke-Flow Characteristics

OY-G01-T-(E)20

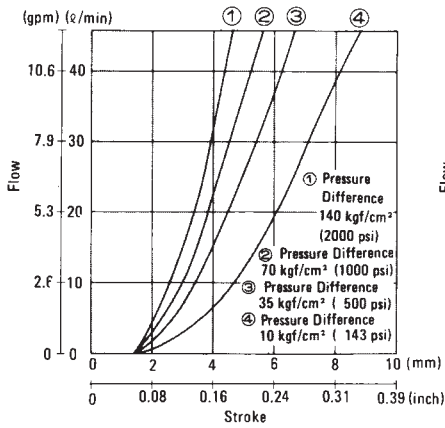

OCY-G01-P-(E)20

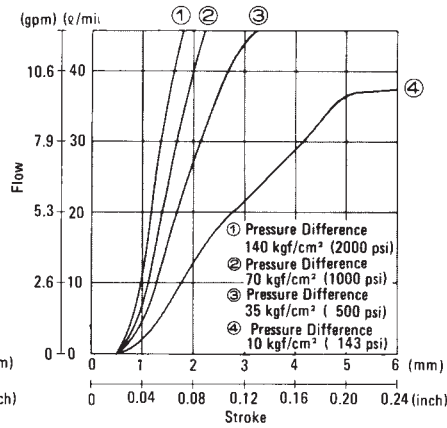

OCY-G01-A-X-Y-(E)20

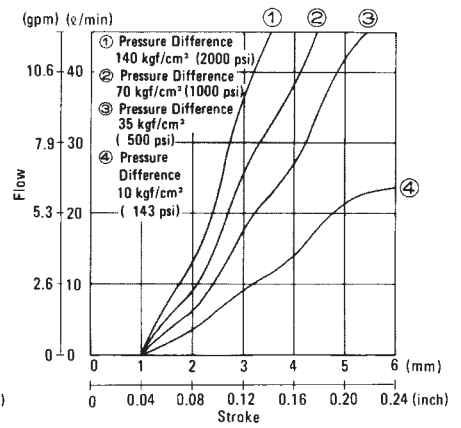

OCY-G03-P-J50

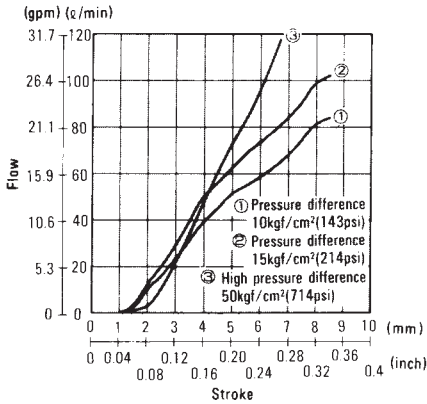

OCY-G03-A-X-Y-J50

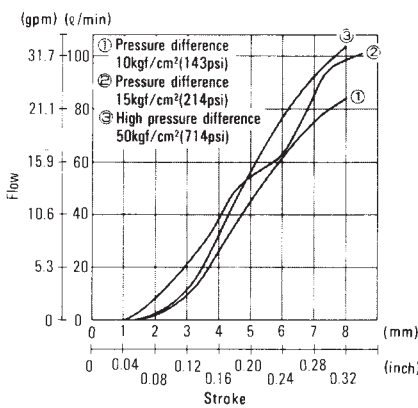

OCY-G06-P-10

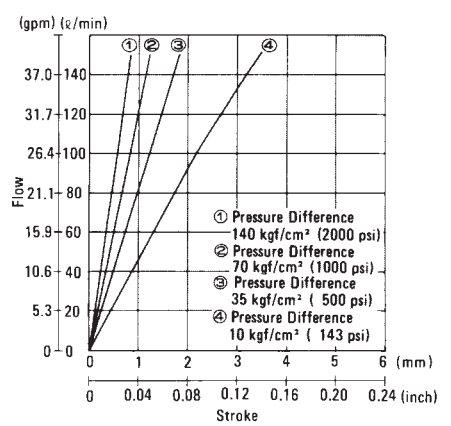

OCY-G06-A-X-Y-11

