

SS Series / WET TYPE SOLENOID (OIL IMMERSED SOLENOID) OPERATED DIRECTIONAL CONTROL VALVE.

350 kgf/cm² {5000 psi}, 100 l/min {26.4gpm}

Wet Type (Oil Immersed) Solenoid

- Smooth, Long Life Wet Type
- High Guide Back Pressure
- Welded type guide
- Compact and Powerful Solenoid

Wiring Box

- Large Wiring Space
- Standard Indicator Lights
- Electrical Surge Control Type (Option G)
- Simple Water Proof Construction

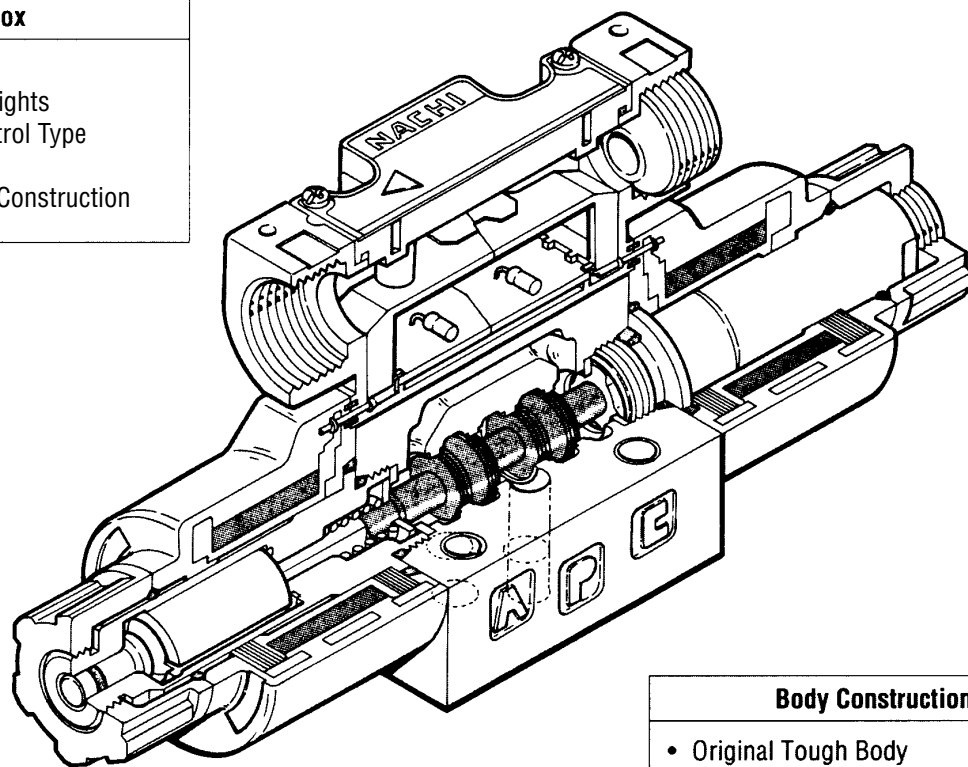

Body Construction

- Original Tough Body
- Low Pressure Loss by Ideal Flow Pass Design
- Stability Operation by Hydraulic Shockless Type (Option F)

Features

- 1. Oil immersed solenoid design**
The moving iron core operates in hydraulic oil for smooth operation and longer life.
- 2. Low noise and quiet operation**
Because the armature is oil immersed there is very little noise during change over.
- 3. Shockless hydraulic operation**
Hydraulic shock caused by abrupt change in the flow condition at flow cut off is minimized by a specially machined spool. (option F)
- 4. High pressure, High flow capacity**
Fluid reaction force compensation and low pressure loss design allows operating pressures of 350 kgf/cm² (5000 psi) and flows to 100 l/min (264 gpm)
- 5. Electrical surge control**
The sparks at the contract and surge voltage, which occur when the solenoid is energized, are minimized (option G)
- 6. Easy wiring**
The wide space makes it easy to wire, check and maintain.
- 7. Easy coil changes**
The plug-in coil can be changed in a single step
- 8. The combination with modular valves allows for compact systems.**

Specifications

Model		Standard type		Shockless type		Standard, Shockless type			
		SA-G01-***-***-30 SS-G01-***-R-***-30		SA-G01-***-F-***-30 SS-G01-***-FR-***-30		SS-G03-***10			
Symbol	Valve spool type	Max. operating pressure kgf/cm ² {psi}	Max. flow ℓ /min {gpm}	Max. operating pressure kgf/cm ² {psi}	Max. flow ℓ /min {gpm}	Max. operating pressure kgf/cm ² {psi}	Max. flow ℓ /min {gpm}		
	- A2X -	350 {5000}	30 {7.9}	250 {3571}	30 {7.9}	250 {3571}	15 {4.0}		
	- H2X -						50 {13.2}		
	- E2X -								
	- A3X -						80 {21.1}		
	- H3X -								
	- E3X -								
	- A3Z -		65 {17.1}						
	- H3Z -								
	- E3Z -								
	- A5 -		100 {26.4}		50 {13.2}		250 {3571}	80 {21.1}	
	- H5 -								
	- C2 -								
	- C5 -								
	- C9 -								
	- C1S -								
	- C6S -								
	- C1 -								AC:65 {17.1} DC:80 {21.1}
	- C6 -								
	- C4 -	50 {13.2}		40 {10.6}		250 {3571}			50 {13.2}
	- C7Y -								
	- C8 -								

Note) The max. flow of each valve differs depending on the pressure. For details, refer to page 7.

		SA·SS-G01			SS-G03		
		AC solenoid	DC solenoid		AC solenoid	DC solenoid	
			Built-in rectifier			Built-in rectifier	
		C※	E※	D※	C※	E※	D※
Max. operating pressure	P, A, B port	350 kgf/cm ² {5000 psi}			250 kgf/cm ² {3571 psi}		
Max. permissible back pressure	T port	210 kgf/cm ² {3000 psi}			70 kgf/cm ² {1000 psi}		
Changeover frequency (times/min)		300	120	300	240	120	240
Standard	Indicator light	R (Note 1)			R		
Options	Shockless	—	F		—	F	
	Electrical surge control	G (Note 2)	—	G	—	G	
	Push button	N			—		
	Quick return function	—	Q	—	—	Q	—
Weight kg (lbs)	Double solenoids	1.8 {4.0}	2.0 {4.4}		3.5 {7.7}	5.1 {11.2}	
	Single solenoid	1.4 {3.1}	1.5 {3.3}		3.1 {6.8}	4.0 {8.8}	
Recommended operating conditions	Operating temperature range	-20 ~ 70°C {-4 ~ 158°F}			5 ~ 60°C {41 ~ 140°F}		
	Operating viscosity	15 ~ 300 cSt (80 ~ 1400 SUS)					
	Viscosity index	90 or above					
	Filtration	25 μm or less					

Note 1) SA: "R" is not standard.

2) SA: "G" is not available.

Notes

1. Pipe system so that tank line is always filled with oil.
2. Surge pressure should be kept below maximum tank line back pressure rating.
3. When using a 4-way valve as a 2-way or 3-way and blocking unused ports lowers the maximum flow.
4. Keep hydraulic oil clean. (Degree of contamination: NAS grade 12 or better). When petroleum

hydraulic oil is used, it should conform to ISO VG32, 46.

5. Do not exceed permissible voltage range of the coil used.
6. Do not supply electric power to the AC solenoid unless the coil is mounted to the valve.
7. Provide drain piping from the T port, when valve spool types are A2X, H2X, E2X.
8. The size 03 rectified solenoid coil can be used for both 50 Hz and 60 Hz. Connect to the COM and 50Hz terminals.

9. If the changeover position is kept under high pressure for an extended period, malfunctions may occur due to hydraulic lock. Please consult us when you have such application.
10. When the detent-type (E2X, E3X, E3Z) is used, we recommend that the electric power supply be continuous in order that the changeover position may be firmly maintained.
11. Resistance force against the manual override pin changes, depending on the back pressure of the tank line.

Solenoid specifications

Solenoid classification		AC solenoid																
Power source		C1		C115			C2			C230								
Voltage (V)		AC100		AC110	AC110		AC200		AC220		AC220	AC230						
Frequency (Hz)		50	60	60	50	60	60	50	60	60	50	60	60					
Size 01	Solenoid coil type	SS type		EDC64-C1			EDC64-C115			EDC64-C2			EDC64-C230					
		SA type		EAC64-C1			EAC64-C115			EAC64-C2			EAC64-C230					
	Starting current (A)		2.2	2.0	2.2	2.0	1.8	2.0	1.1	1.0	1.1	1.0	0.91	1.0				
	Holding current (A)		0.52	0.38	0.46	0.47	0.35	0.42	0.26	0.19	0.23	0.24	0.17	0.21				
	Holding electric power (W)		25	22	28	25	22	28	25	22	28	25	22	28				
	Permissible voltage range (V)		80 ~ 110		90 ~ 120		90 ~ 120		100 ~ 130		160 ~ 220		180 ~ 240		180 ~ 240		200 ~ 260	
Insulation resistance (MΩ)		100 or above (500V)																
Size 03	Solenoid coil type	EC64-C1			EC64-C115			EC64-C2			EC64-C230							
		Starting current (A)		3.6	3.7	3.5	3.0	—	3.3	1.8	1.8	1.7	1.5	—	1.6			
	Holding current (A)		0.90	0.86	0.80	0.69	—	0.75	0.45	0.43	0.40	0.35	—	0.38				
	Holding electric power (W)		37	37	37	30	—	37	37	37	37	30	—	37				
	Permissible voltage range (V)		90 ~ 110		100 ~ 120		100 ~ 130		100 ~ 130		180 ~ 220		200 ~ 240		200 ~ 260		200 ~ 260	
	Insulation resistance (MΩ)		100 or above (500V)															

SS/SA Series

Solenoid classification		DC solenoid								
		Built-in rectifier					D1	D2		
Power source		E1	E115		E2	E230				
Voltage (V)		AC100	AC110	AC115	AC200	AC220	AC230	DC12	DC24	
Frequency (Hz)		50/60	50/60		50/60	50/60		—	—	
Size 01	Solenoid coil type	SS type	EDC64-E115		EDC64-E2	EDC64-E230		EDC64-D1	EDC64-D2	
		SA type	EAC64-E115		EAC64-E2	EAC64-E230		EAC64-D1	EAC64-D2	
	current (A)		0.37	0.31	0.32	0.18	0.15	0.16	2.5	1.25
	Holding electric power (W)		32	30	32	32	30	32	30	30
	Permissible voltage range (V)		90 ~ 100	100 ~ 125		180 ~ 220	200 ~ 250		10.8 ~ 13.2	21.6 ~ 26.4
Insulation resistance (MΩ)		100 or above (500V)								
Size 03	Solenoid coil type		EC64-E115		EC64-E2	EC64-E230		EC64-D1	EC64-D2	
	current (A)		0.40	0.32	0.33	0.20	0.17	0.18	2.9	1.45
	Holding electric power (W)		35	30	33	35	32	35	35	35
	Permissible voltage range (V)		90 ~ 110	100 ~ 125		180 ~ 220	200 ~ 250		10.8 ~ 13.2	21.6 ~ 26.4
	Insulation resistance (MΩ)		100 or above (500V)							

Model Code

SA
SS - G01 - A3Z - ※R - C230 - (J)30

- Design No.
30: Valve size 01
10: SS-G03
- Mounting bolt
No code : Metric thread (Valve size 01)
J : Metric thread (Valve size 03)
E : Unified thread
- Electric power source indication
C: AC C1 = AC100V50/60 Hz, C2 = AC200V50/60 Hz
C115 = AC110V50 Hz/AC115V60 Hz
C230 = AC220V50 Hz/AC230V60 Hz
D: DC D1 = DC12V, D2 = DC24V
E: Rectifier built-in type, common to 50/60 Hz
E1 = AC100V, E2 = AC200V, E115 = AC115V, E230 = AC230V
- R: Indicator light (Standard for SS series)
- Optional function (can be combined in the alphabetical order)
F: Hydraulic shockless type (Electric power D※ or E※)
G: Electrical surge contorol (Electric power D※ for 01/03, C※ for G01)
N: With push button for manual operation (size 01) See page DV-7
Q: Quick return type (Electric power E※)

Flow passage condition during transition

X	Y	Z
Closed	Semi-open	Open

Position type at neutral

0 	1 	2 	3 	4 	5
6 	7 	8 	9 	1S 	6S

Note: P pressure port, A and B cylinder ports, T(R) tank port.

Spring arrangement

A	H	C	E
Spring offset	Spring offset	Spring center	Detent

Valve size 01: Size 01 03: Size 03

Gasket mounting

SA series: DIN connector type

SS series: Terminal box type

SS/SA Series

Option

Hydraulic Shockless Model
Option F
Valve model: SS-GO※-※※-FR-※※-※30(10)

Features

- Smooth start and stop performance
- Quiet operation
- Long life and reliable operations

Effects

- Eliminates shocks in the piping system.
- Prevents the piping connections from leaking oil.
- Extends the life of the hydraulic components.
- Maintenance-free operation of the hydraulic system.

Pressure changeover waveform
Dry solenoid valve

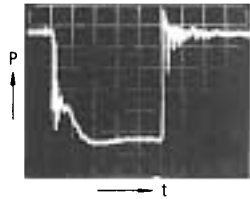

Photo 1.

Hydraulic shockless solenoid valve

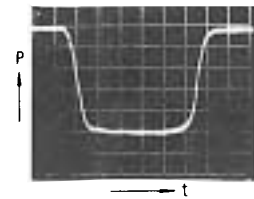

Photo 2.

Electrical Surge Control Model
Option G
Valve model: SS-GO※-※※-GR-※※-※30(10)

Features

- Suppresses the surge voltage.
- Eliminates sparks between relay contacts.
- Extends the life of the relay contact.

Effects

- Improves the reliability of the control relay.
- Extends the life of conventional relays.
- Can be operated with a miniature relay.
- The RAC rectifier built-in DC model eliminate sparks at the control relay contact. It can be directly operated with a PLC (programmable logic controller).

Electrical surge waveform
Standard DC solenoid

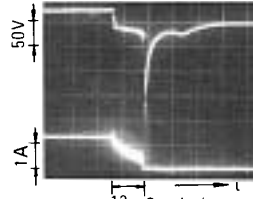

Photo 3.

Electrical surge control DC solenoid

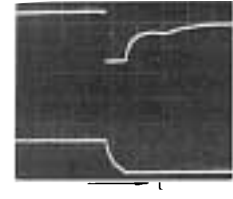
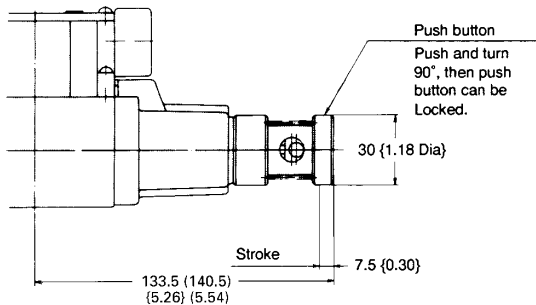

Photo 4.

Push Button for Manual Operation
Option N
Valve model: SS-GO1※-※※-NR-※※-※30



Note 1. G01 type only.
2. () dimensions show for DC solenoid valve.

Quick Return Model
Option Q
Valve model: SS-GO※-※※-QR-※※-※30(10)

Handling

- By using quick return model (Option Q), spring return time of the electric power E ※ (Rectifier built-in type) becomes shorter (Same to that of electric power D ※).
- Quick return equipment is built-in the terminal box with the solenoid valve.

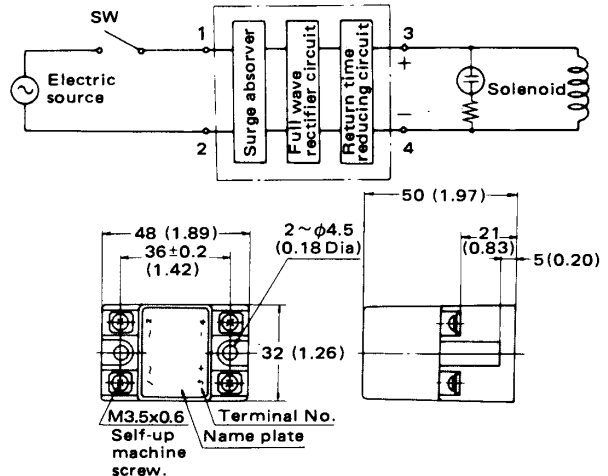

SS/SA Series

Performance Curve

Pressure drop characteristics

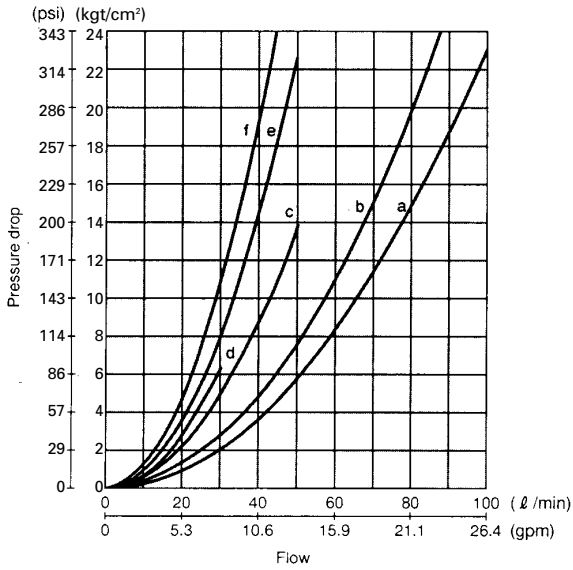

Model	Valve spool type	P→A	P→B	A→T	B→T	P→T
SS-G01 SA-G01	A2X, H2X, E2X	d	d	—	—	—
	A3X, H3X	b	b	b	b	—
	E3X	b	b	b	b	—
	A3Z, H3Z, E3Z	a	a	a	a	—
	C4	a	a	a	a	a
	A5, H5, C5, C6S	b	b	b	b	—
	C1, C1S	b	b	a	b	—
	C2	a	b	b	b	—
	C6	b	b	a	a	—
	C7Y	f	f	e	e	c
C8	a	f	b	e	c	
C9	a	a	b	b	—	

Viscosity of hydraulic fluid 32 cSt {150 SUS}

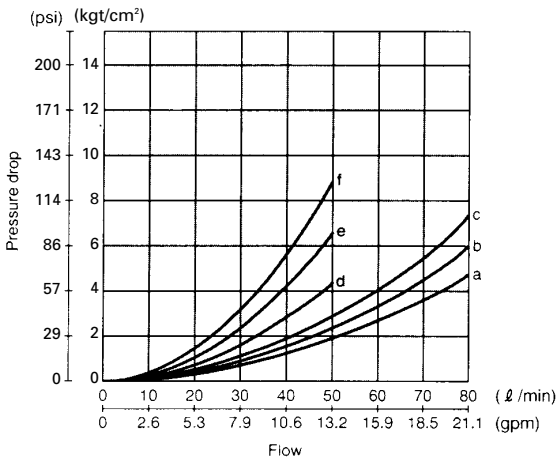

Model	Valve spool type	P→A	P→B	A→T	B→T	P→T
SS-G03	A2X, H2X, E2X	c	c	—	—	—
	A3X, H3X, E3X A5, H5, C5, C6S	a	a	c	c	—
	A3Z, H3Z, E3Z	a	a	a	b	—
	C1, C1S	a	a	a	c	—
	C2	a	a	c	c	—
	C4	a	a	a	b	c
	C6	a	a	a	b	—
	C7Y, C8	f	f	e	e	d
C9	a	a	c	c	—	

Viscosity of hydraulic fluid 32 cSt {150 SUS}

SS/SA Series

Pressure-flow characteristics

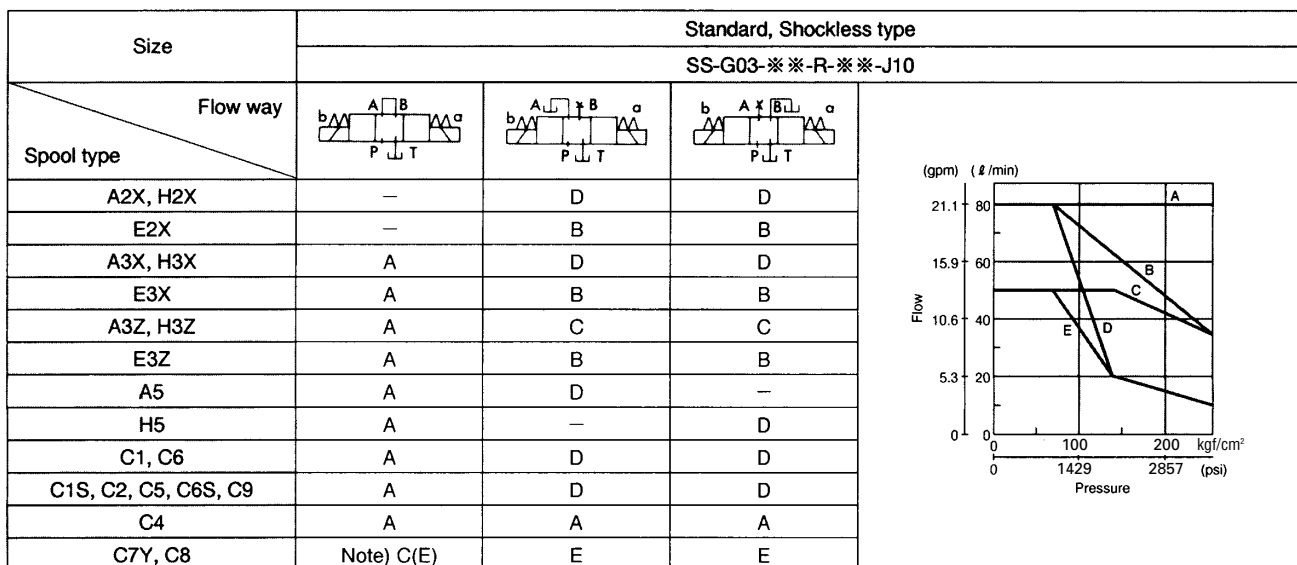
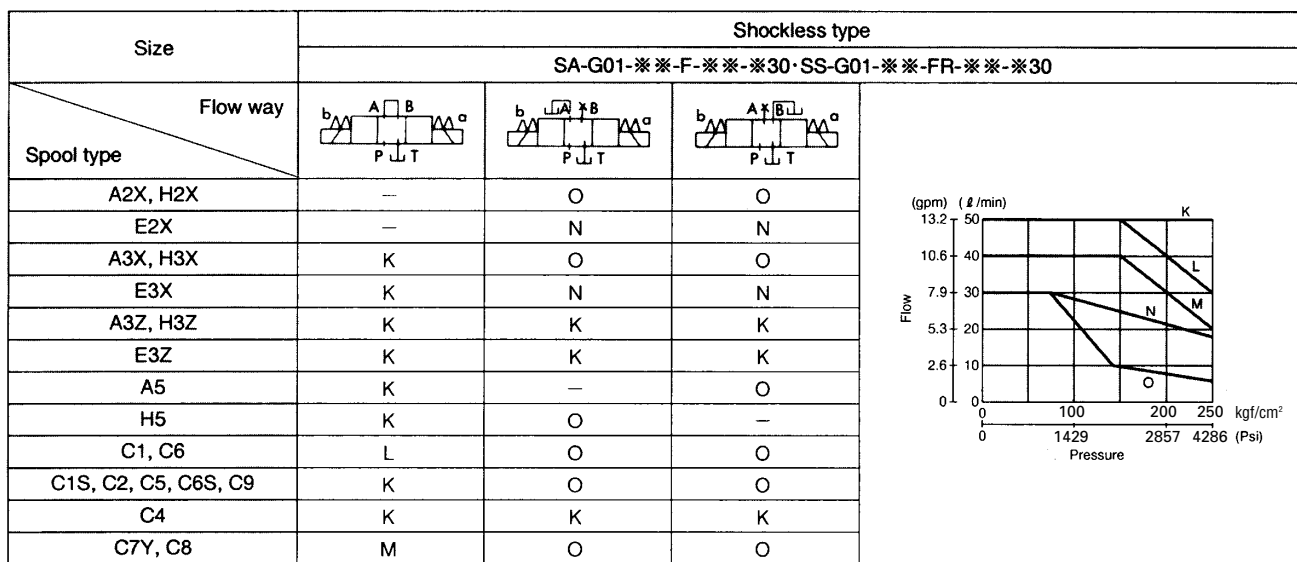
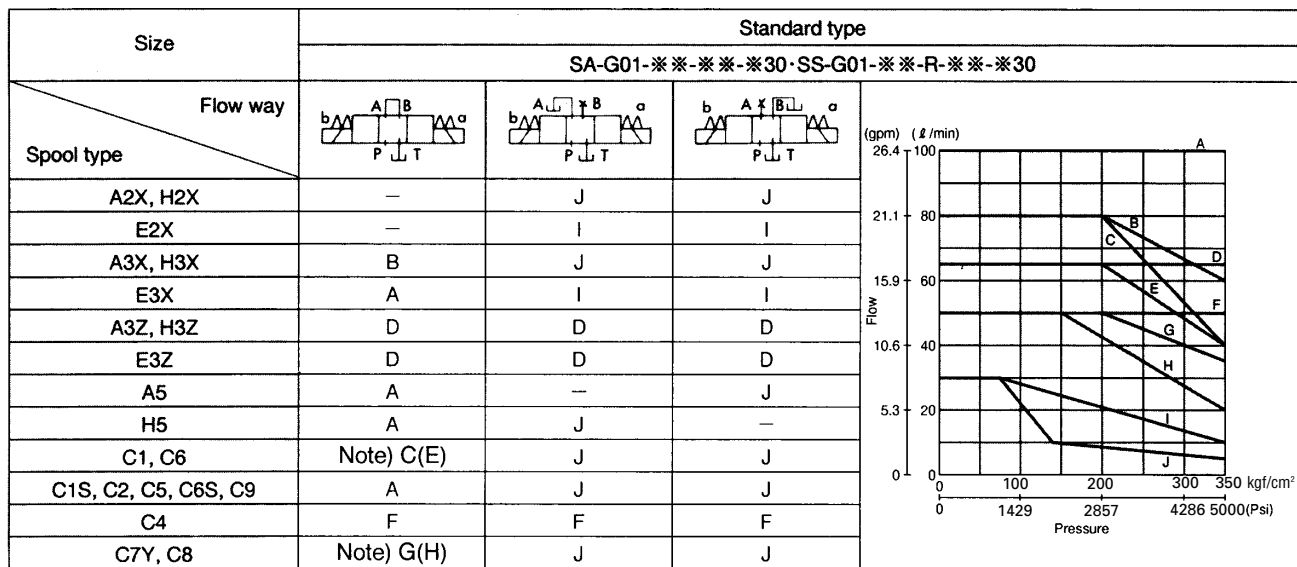

Note) In the case of rectifier built-in type solenoid valve, pressure-flow characteristics becomes (E), (H).