

ROBOT

Total Robot Catalog

Safety precautions

- Before using any robot, review all documentation including operating instructions and other attached documents. Familiarize yourself with the contents in order to ensure proper robot operation.
- When a robot is to be used for an application where robot operation may directly threaten the life or cause physical harm to personnel, a careful examination of its intended use is required. Contact a NACHI-FUJIKOSHI sales representative to provide details of the intended use. Obtain proper training prior to operating robot.
- Photos used in this document show the robots without safety fences, equipment, and devices that are required to comply with the applicable laws and regulations for ensuring safety. These photos are only provided to illustrate what is being described.
- The external appearances, specifications, etc. of the products portrayed in this catalog are subject to change without notice due to improvements in performance.

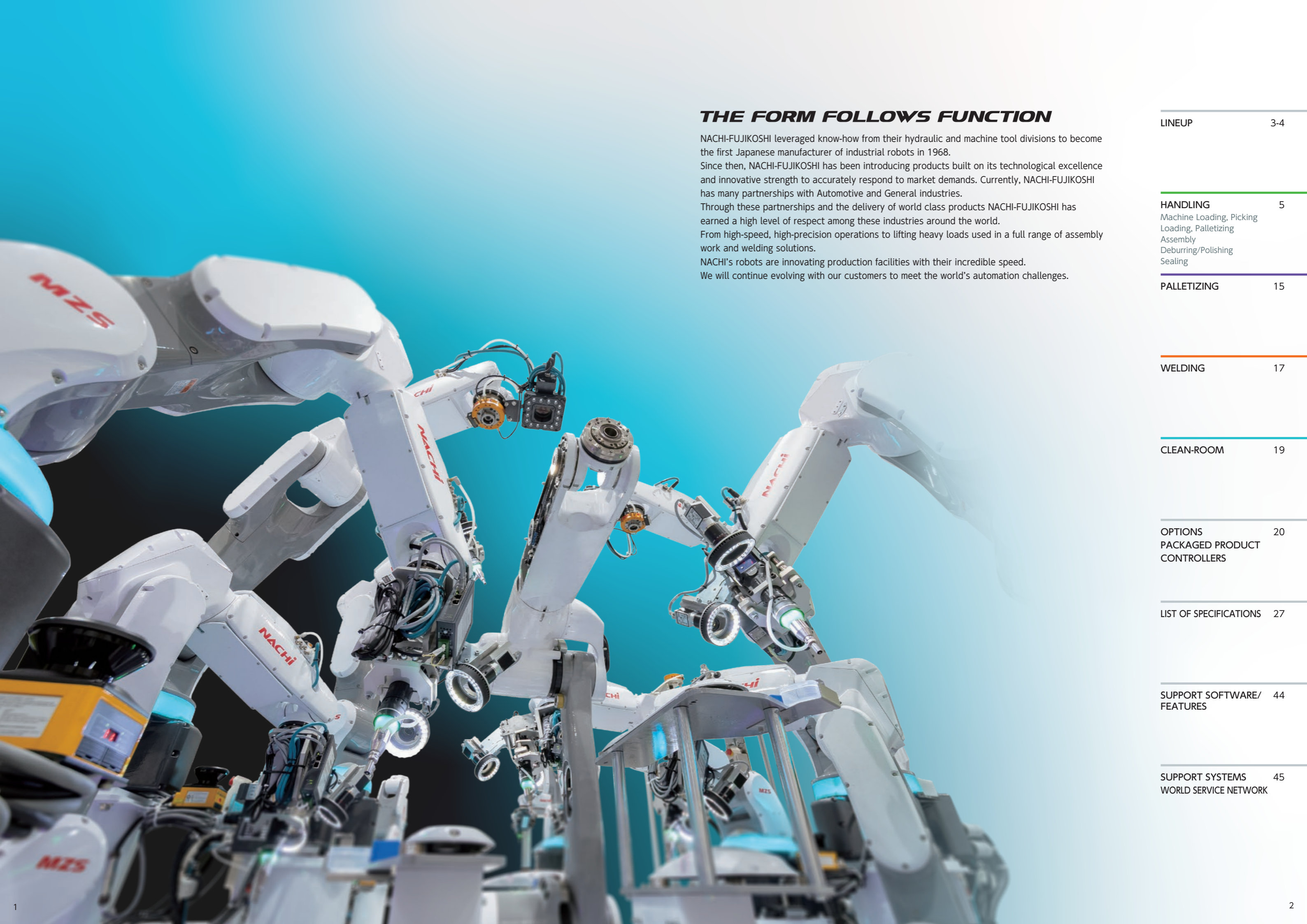

THE FORM FOLLOWS FUNCTION

NACHI-FUJIKOSHI leveraged know-how from their hydraulic and machine tool divisions to become the first Japanese manufacturer of industrial robots in 1968. Since then, NACHI-FUJIKOSHI has been introducing products built on its technological excellence and innovative strength to accurately respond to market demands. Currently, NACHI-FUJIKOSHI has many partnerships with Automotive and General industries. Through these partnerships and the delivery of world class products NACHI-FUJIKOSHI has earned a high level of respect among these industries around the world. From high-speed, high-precision operations to lifting heavy loads used in a full range of assembly work and welding solutions. NACHI's robots are innovating production facilities with their incredible speed. We will continue evolving with our customers to meet the world's automation challenges.

LINEUP 3-4

HANDLING 5
Machine Loading, Picking
Loading, Palletizing
Assembly
Deburring/Polishing
Sealing

PALLETIZING 15

WELDING 17

CLEAN-ROOM 19









OPTIONS 20
PACKAGED PRODUCT
CONTROLLERS

LIST OF SPECIFICATIONS 27

**SUPPORT SOFTWARE/
FEATURES** 44

SUPPORT SYSTEMS 45
WORLD SERVICE NETWORK

LINEUP

		HANDLING				HANDLING		PALLETIZING	WELDING	CLEAN-ROOM
		MZ	MC/MR	MZS SERIES/CZ	EC	EZ	MC and SC Heavy Loader	LP/MC	Hollow Wrist	ST-C
Process and application	Field									
Number of controlled axes		5 or 6 axes	6 or 7 axes	6 axes	4 axes		4 axes	6 axes	4 or 5 or 6 axes	6 axes
Payload capacity		1 to 70kg	20 to 70kg	5 to 12kg	6 to 10kg		3kg	280 to 1000kg	130 to 500kg	100 to 300kg
Maximum reach		350 to 2,502mm	1,260 to 2,050mm	927 to 1,300mm	500 to 1,000mm		450 to 550mm	2,771 to 3,972mm	2,771 to 3,756mm	1,634 to 3,383mm
Page Number		5	8	9	11		12	13	15	17
Spot welding/ Seam welding	Automotive Automotive parts		●					●	●	
Arc welding	Metalworking Agricultural machinery Construction machinery		●							
Die casting	Automotive parts	●	●	●				●	●	
Resin molding	Plastics Electric and electronics	●	●	●				●	●	
Press operation handling								●	●	
Machine loading		●	●	●				●	●	
Deburring/Polishing		●	●						●	
Sealing	Automotive Automotive parts Machine tools Plastics	●	●	●					●	
General Assembly	Pharmaceuticals and cosmetics Electric and electronics	●	●	●	●	●	●	●	●	
Bolt tightening	Metalworking Chemistry	●	●	●	●	●	●		●	
Picking, aligning, packaging	Medical equipment Foodstuffs Agricultural machinery	●	●	●	●	●	●	●		
Shipping and receiving (palletizing)	Construction machinery	●	●	●				●	●	
Measuring, inspection, testing		●	●	●	●	●	●			●
Material handling		●	●	●	●	●	●	●	●	
Glass substrate loading	Electric and electronics									●

●: Described typical applications

Handling robot

- Machine loading
- Picking
- Loading
- Assembly
- Palletizing
- Deburring/Polishing
- Sealing

High speed/High precision compact robot

MZ SERIES

High speed/High precision compact robot available in protection against dust and water, multiple installation orientations. Large selection of payload from 1 to 70kg. The internal wire routing for the tooling significantly increases cabling reliability so that operations in a narrow space are possible. Wide operating range improves productivity and also high spec/ performance applications such as vision sensor are available. Meets various automation needs.

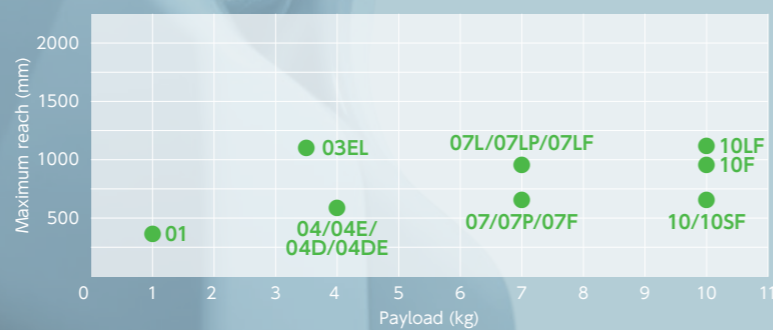

MZO1

High speed and high precision 1kg compact robot.

- Number of controlled axes 6 axes
- Payload 1kg
- Maximum reach 350mm



MZO4

Downsizes facility with light-weight compact body. Sophisticated and flowing form. Smooth surface design, easy to clean covers.

- Number of controlled axes 6 axes
- Payload 4kg
- Maximum reach 541mm



MZO7/MZO7L

Meets various automation needs with various options.

- Number of controlled axes 5 or 6 axes
- Payload 7kg
- Maximum reach MZO7 : 723mm
MZO7L: 912mm



MZ10

10 kg payload with the same dimensions and workspace as MZO7.

- Number of controlled axes 6 axes
- Payload 10kg
- Maximum reach 723mm



MZO3EL

Maximum reach 1,102mm with 3.5kg payload. Compact long arm robot.

- Number of controlled axes 6 axes
- Payload 3.5kg
- Maximum reach 1,102mm



MZO7F/MZO7LF MZ10SF/MZ10F NEW

Achieves even higher speed and precision while MZO7 series features, lightweight, compact body, and hollow wrist are maintained.

- Number of controlled axes 6 axes
- Payload 7 to 10kg
- Maximum reach MZO7F, MZ10SF: 723mm
MZO7LF, MZ10F: 912mm



MZ10LF

Achieves payload improvement, longer reach, and higher speed and precision while MZO7 series features, lightweight, compact body, and hollow wrist are maintained.

- Number of controlled axes 6 axes
- Payload 10kg
- Maximum reach 1,202mm

NEW MZ12/MZ12H/MZ15H

IP 67 equivalent (dust-proof, moisture-resistant), with rust proof/coolant resistant paint. Powerful and slim multi purpose compact robot.

- Number of controlled axes 6 axes
- Payload 12 to 15kg
- Maximum reach 1,454mm



NEW MZ25/MZ35S

Supports various applications with large operating range and powerful wrist.

- Number of controlled axes 6 axes
- Payload 25 to 35kg
- Maximum reach 1,882mm



NEW MZ12W

Space-saving/wall mount type robot. Large wrist torque allows for use with large hands. Ideal for storing racks in the board transport process, etc. The hand can be inserted in various directions with a free control posture that takes advantage of the vertical multi-joint structure.

- Number of controlled axes 6 axes
- Payload 12kg
- Maximum reach 1,564mm



Powerful and compact multi-purpose robot

MC SERIES

High dust-proof and moisture-resistant, combined with outstanding performance and a full range of functions to handle a variety of applications make these robots ideally suited for a variety of production environments.

- Number of controlled axes 6 axes
- Payload 35 to 70kg
- Maximum reach 2,050mm



NEW MZ35F/50F/70F/50LF

Space-saving with lightweight/slim body. Adopts a hollow wrist structure to avoid interference with peripheral equipment. Flexible operation even in narrow spaces.

- Number of controlled axes 6 axes
- Payload 35 to 70kg
- Maximum reach 2,102 to 2,502mm



Hollow wrist

Flexible motion "Arm" robot with 7-axes

MR SERIES

With a programmable pose, this 7-axis arm design can handle complex motions to flexibly work in processes that other robots cannot. The compact robot arm greatly reduces the amount of space needed for installations.

- Number of controlled axes 7 axes
- Payload 20 to 50kg
- Maximum reach 1,260 to 2,050mm



Press operation handling robot ST210TP

Its highly rigid, vibration-dampening design enables exceptional speed. The newly developed specialized press arm attachment provides a much greater reach, accommodating press pitches of up to eight meters. It moves parts horizontally at high speed for efficient press operation.

- Number of controlled axes 7 axes
- Payload 80kg
- Maximum reach 3,106mm

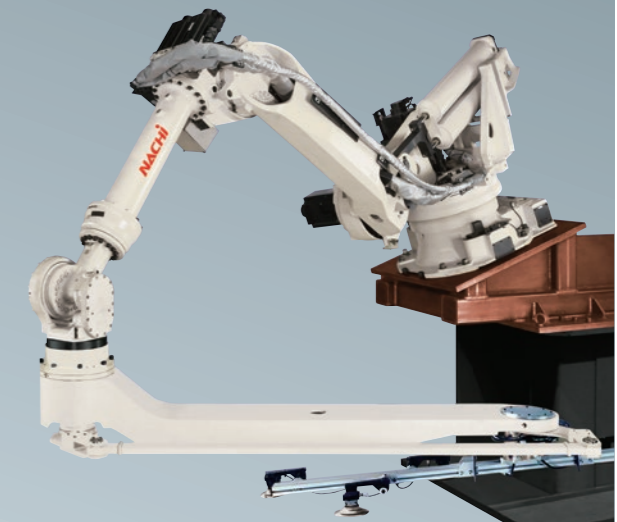

Rack storage

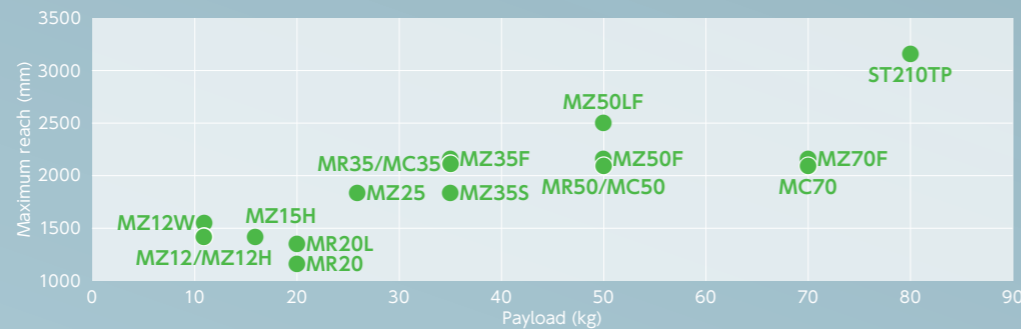

Picking

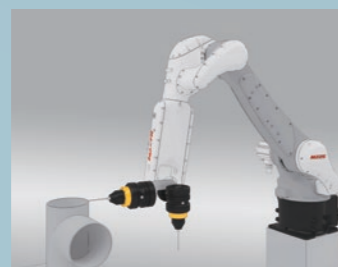

Deburring/Polishing

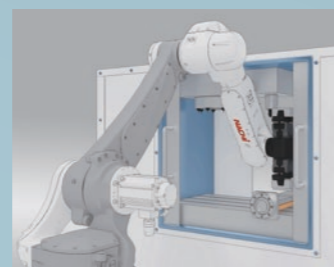

Machine loading



Assembly



Handling/Transfer



Press-tending

Collaborative robot

- Picking
- Assembling support
- Assembly
- Machine loading



People-friendly collaborative robot

MZS SERIES CZ

NACHI's collaborative robots MZS SERIES and CZ10 are fully loaded with human-friendly functions. Safety fences are not required and makes it easier to install a robot with various applications.

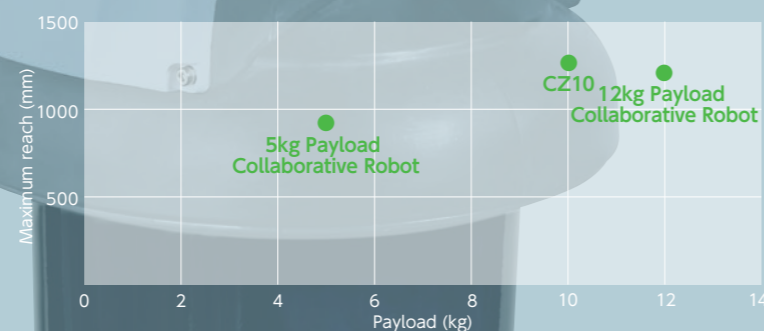

5kg Payload Collaborative Robot

Collaborative robots with high rigidity and safety design that complies with safety standards ISO10218-1/13849-1/TS15066, achieving both high-speed/high-precision performance and safety. Hand wiring is routed through the hollow wrist to avoid interference with peripheral equipment. It can operate flexibly even in narrow spaces and contributes to smarter lines.

- Number of controlled axes 6 axes
- Payload 5kg
- Maximum reach 927mm



12kg Payload Collaborative Robot

A collaborative robot built on trusted MZ Series technology, now offering a longer reach and capable of handling 12 kg payloads with high speed and precision.

- Number of controlled axes 6 axes
- Payload 12kg
- Maximum reach 1,214mm



CZ10

People-friendly design

People-friendly design with rounded arms and gap between joints.

- Number of controlled axes 6 axes
- Payload 10kg
- Maximum reach 1,300mm

Awarded the certification by certification organization. Safety certification : Conforming to ISO 10218-1 Conforming to TS 15066



Picking



Assembling support



Assembly



Machine loading

SCARA robot

SCARA robot

EC SERIES

The EC06 series are simple structure robots with high-speed & high precision. They meet the needs for applications such as assembling & handling.

We have a lineup of a wide range of maximum reach from 500 to 1,000 mm.

Furthermore, the hollow structure at the tip of the wrist simplifies piping and wiring from the robot body to various tools.



EC10

The lineup includes four robot types with different maximum reaches and vertical strokes.

The hollow shaft design simplifies wiring, prevents interference with peripheral equipment, and enables a more compact equipment layout.

- Number of controlled axes 4 axes
- Payload 10kg
- Maximum reach 800 to 1,000mm



WING SLICER Type robot

EZ

The EZ robots are high-speed, horizontally articulated & equipped with a space-saving vertical first axis.

They have a high speed, high accuracy structure that is excellent for applications such as assembly and handling. Cable routing is simplified by the hollow construction through the end of the wrist, capable of routing cables through.

The internal wire routing for the tooling significantly increases cabling reliability.

The Wing Slicer family has multiple models with varying reach and payload to support a variety of equipment operations.

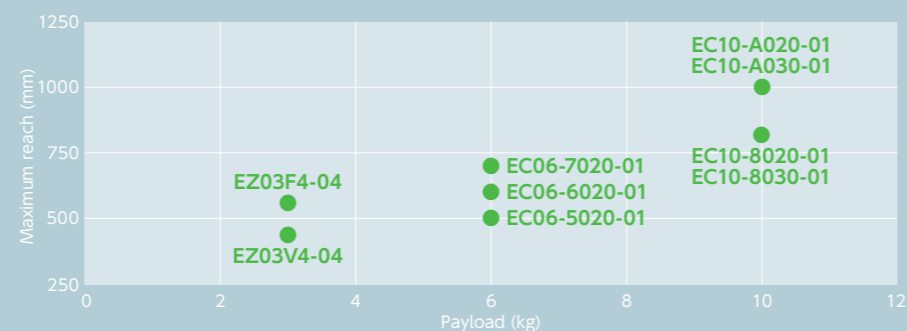

Packing



Inspection



Assembling

Super heavy loader robot

Automobiles' body handling etc.

With high wrist torque and large operating envelope, these robots are opening up a new era of heavy loading robots.

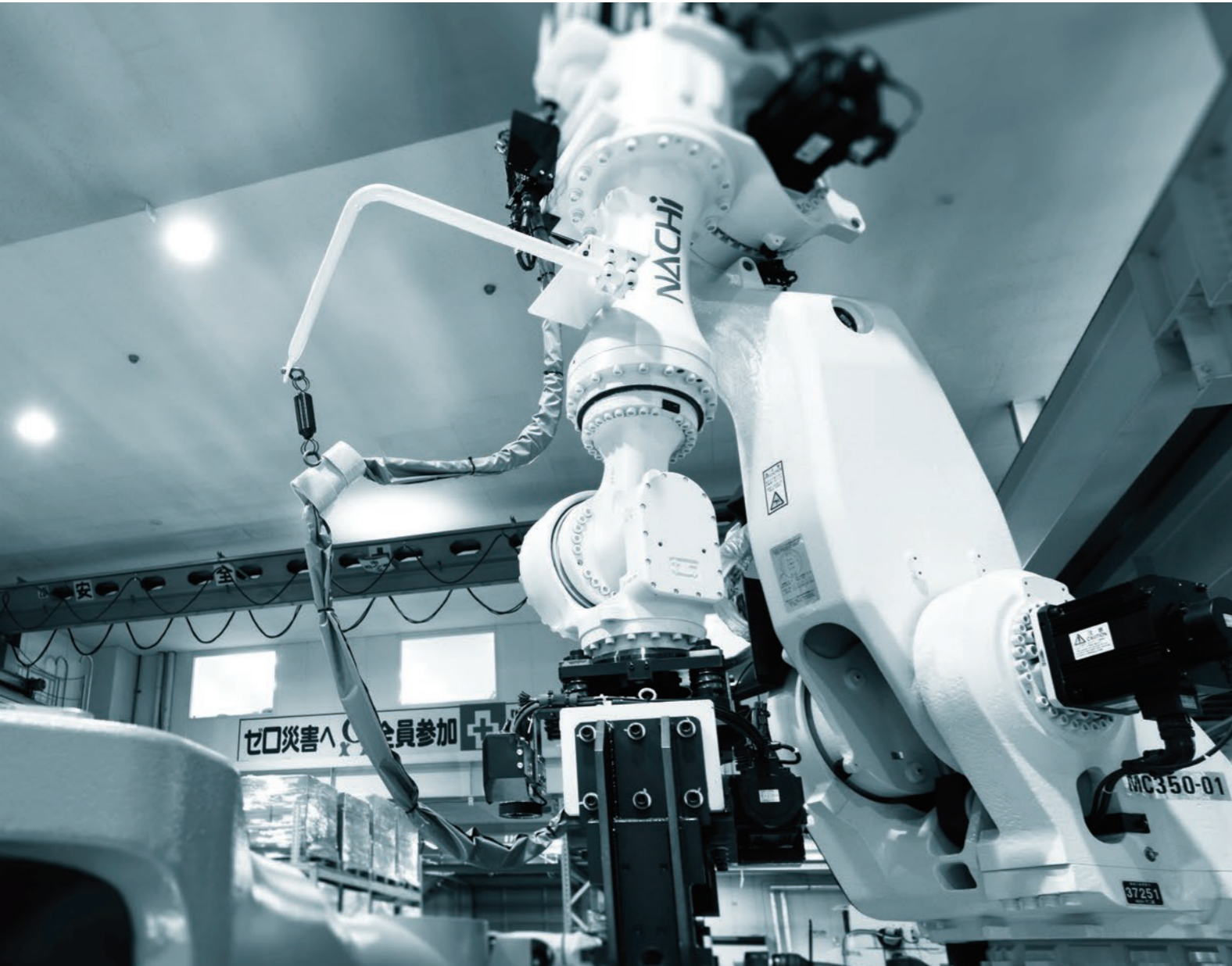

Super heavy loader robot

MC HEAVY LOADER SERIES

Tool cables and hoses routed inside the hollow arm provides excellent life.



MC1000DL

- Number of controlled axes 6 axes
- Payload 1,000kg
- Maximum reach 3,972mm



MC600

- Number of controlled axes 6 axes
- Payload 600kg
- Maximum reach 2,890mm



SC700DL

- Number of controlled axes 6 axes
- Payload 700kg
- Maximum reach 3,972mm

SC HEAVY LOADER

The SC heavy loader robots, with huge load capacity and reach, are excellent for jobs that require heavy lifting. Their large vertical stroke allows more flexible production lines by replacing conventional specialized machinery, such as auto body lifters, with robots.

Palletizing robot

High-speed palletizing robot
Heavy loader palletizing robot

NACHI's palletizing robots help with intricate palletizing of boxes, crates and sacks for shipping and receiving processes.

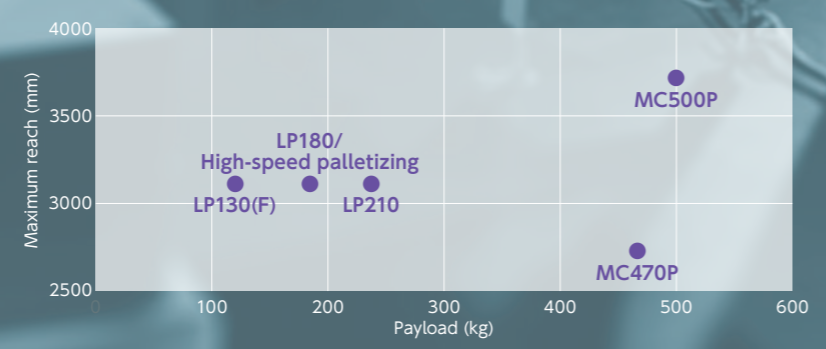
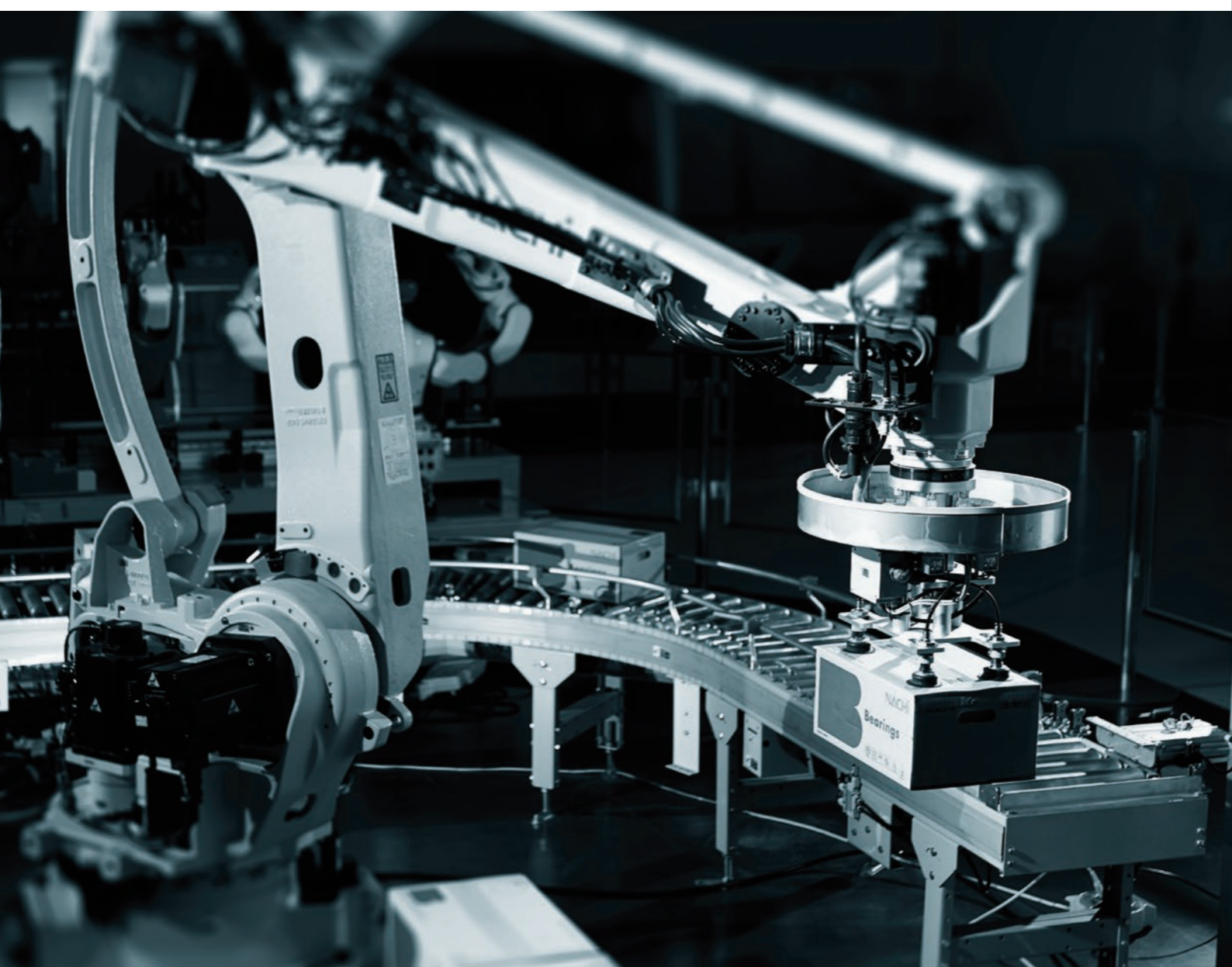

High-speed palletizing robot

LP SERIES

The LP series of specialized palletizing robots do large movements quickly. They can stack products, such as cardboard boxes, or products in bags, such as foodstuffs or chemicals, onto pallets at high speeds. Loaded with palletizing functions, they can handle a wide variety of stacking patterns.

- Number of controlled axes 4 axes
- Payload 130 to 210kg
- Maximum reach 3,210mm

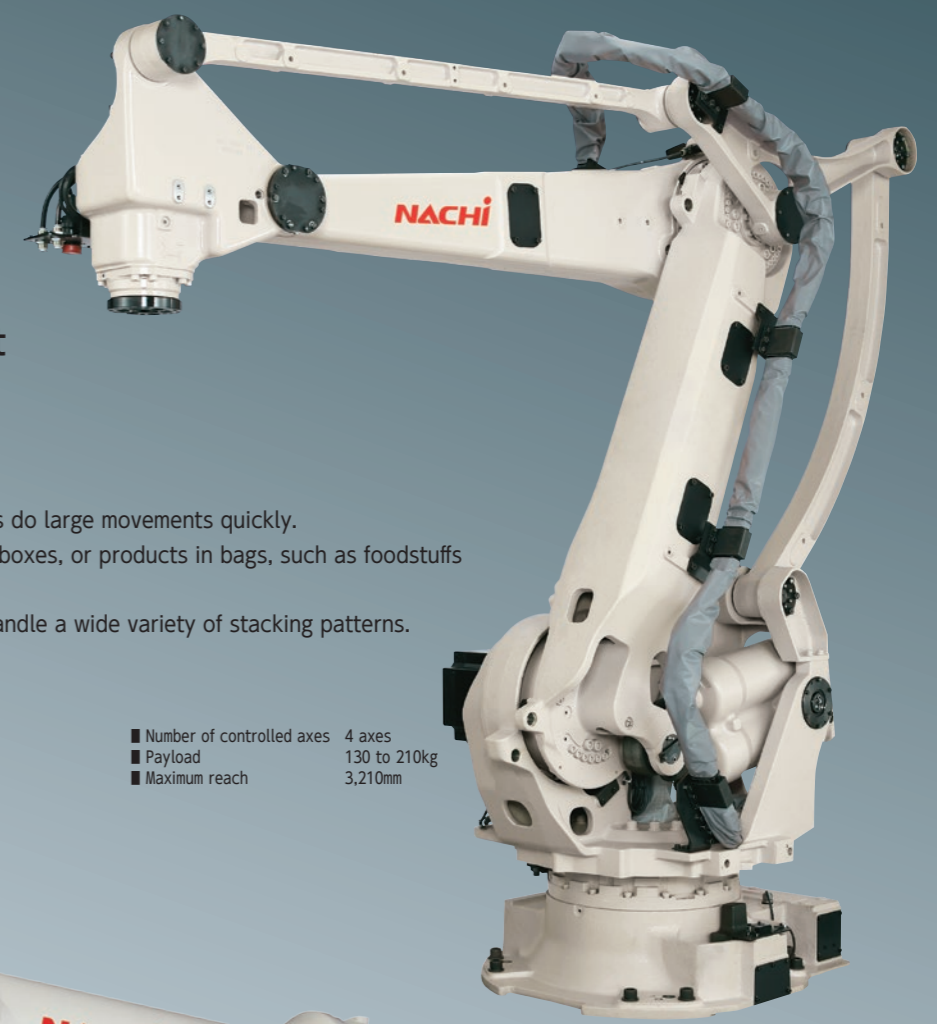

Heavy loader palletizing robot

MC SERIES

This robot has enough lifting power to handle jobs of loading and stacking beverages, bricks, plastic resins, concrete and other heavy goods.

- Number of controlled axes 5 or 6 axes
- Payload 470 to 500kg
- Maximum reach 2,771 to 3,756mm



Palletizing

Spot welding robot

Welding robots are the central element of automobile production, especially the auto body welding lines. The performance, functionality, and reliability of the NACHI lineup of spot welding robots are supporting the world of manufacturing.



Spot welding robot with built-in cables

The next generation of hollow arm spot welding robots. Cables and hoses for the welding gun are fully enclosed to increase cable reliability and improve rate of operation. Provides a cleaner profile for installing directly in the assembly line and improves operational accuracy of offline programming, including welding cables. This hollow arm model is now available in shelf mount version for 166 kg & 210 kg payloads.

- Number of controlled axes 6 axes
- Payload 100 to 210kg
- Maximum reach 1,634 to 2,951mm

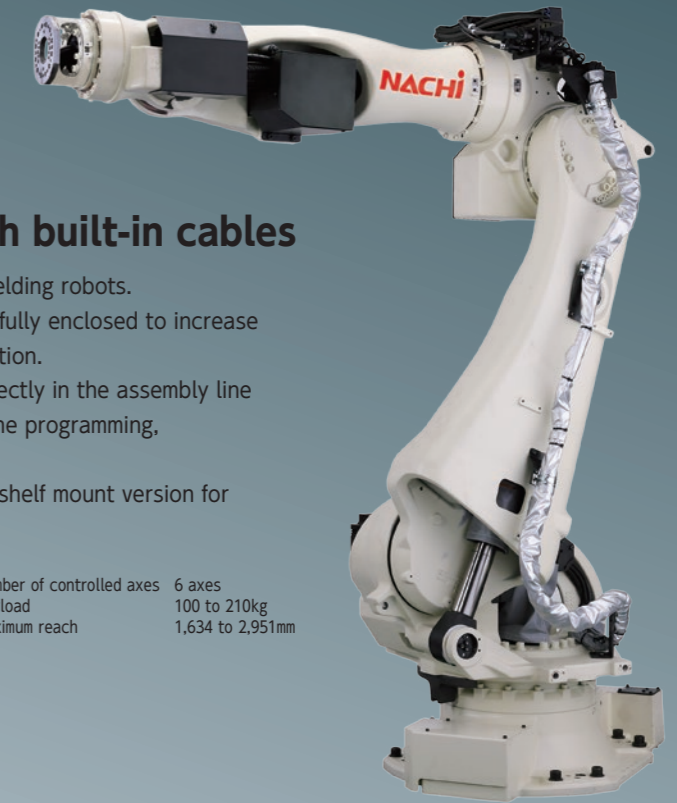

Ultra-fast spot welding robot

The Ultimate Spot Welding Robot. Using higher speeds and vibration damping properties, we greatly improved productivity by shortening cycle times 30% (compared to our previous models) improvements were made in three areas, weight reduction, higher rigidity, and faster controls. The compact design allows for high density installation layouts and maintenance is streamlined making periodic inspections and parts replacement easy to do. The lighter weight and the latest in motor drive controls have reduced power consumption by 15% over previous models reducing environmental impact. A new long arm type with a payload capacity of 210/240 kg is added to the lineup. In addition, the payload can be selected up to a maximum of 300 kg, meeting further needs on site.

- Number of controlled axes 6 axes
- Payload 100 to 300kg
- Maximum reach 1,634 to 3,383mm

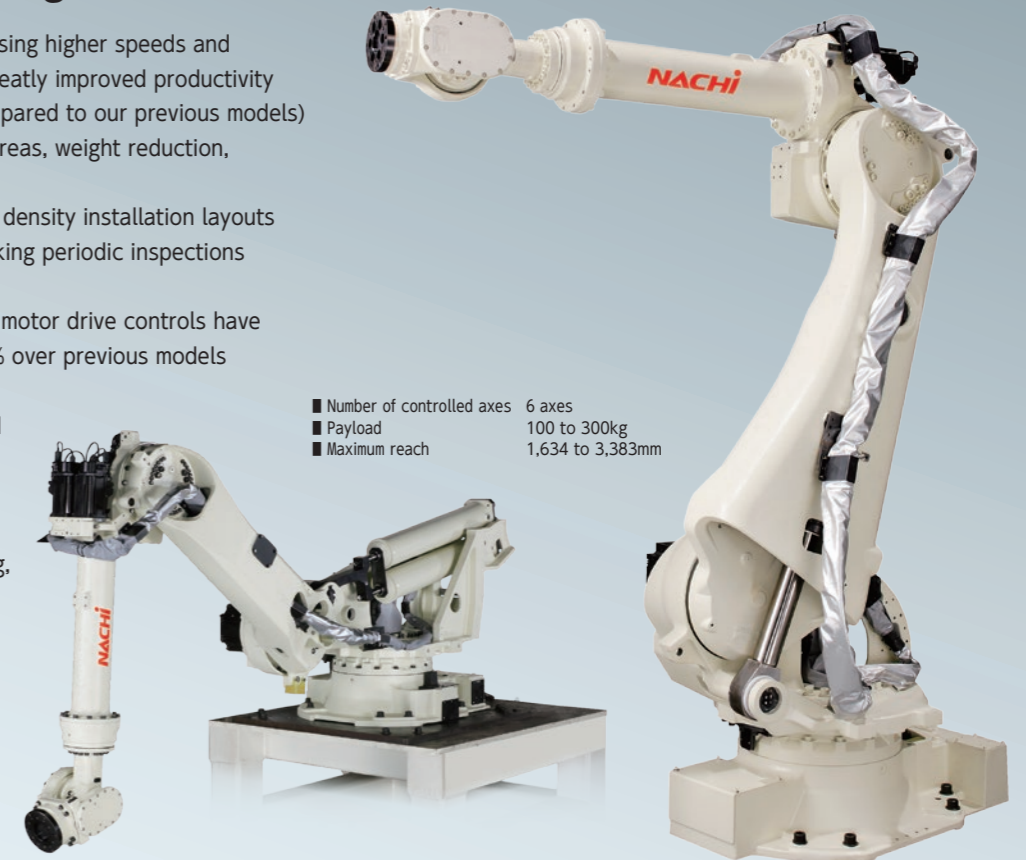

Spot welding

Clean-room robot

Our series of clean-room robots suppress the dust created by arm movements and are designed to be used in clean rooms. These high-performance loading robots support the heart of the flat panel display production process.

Clean-room loading

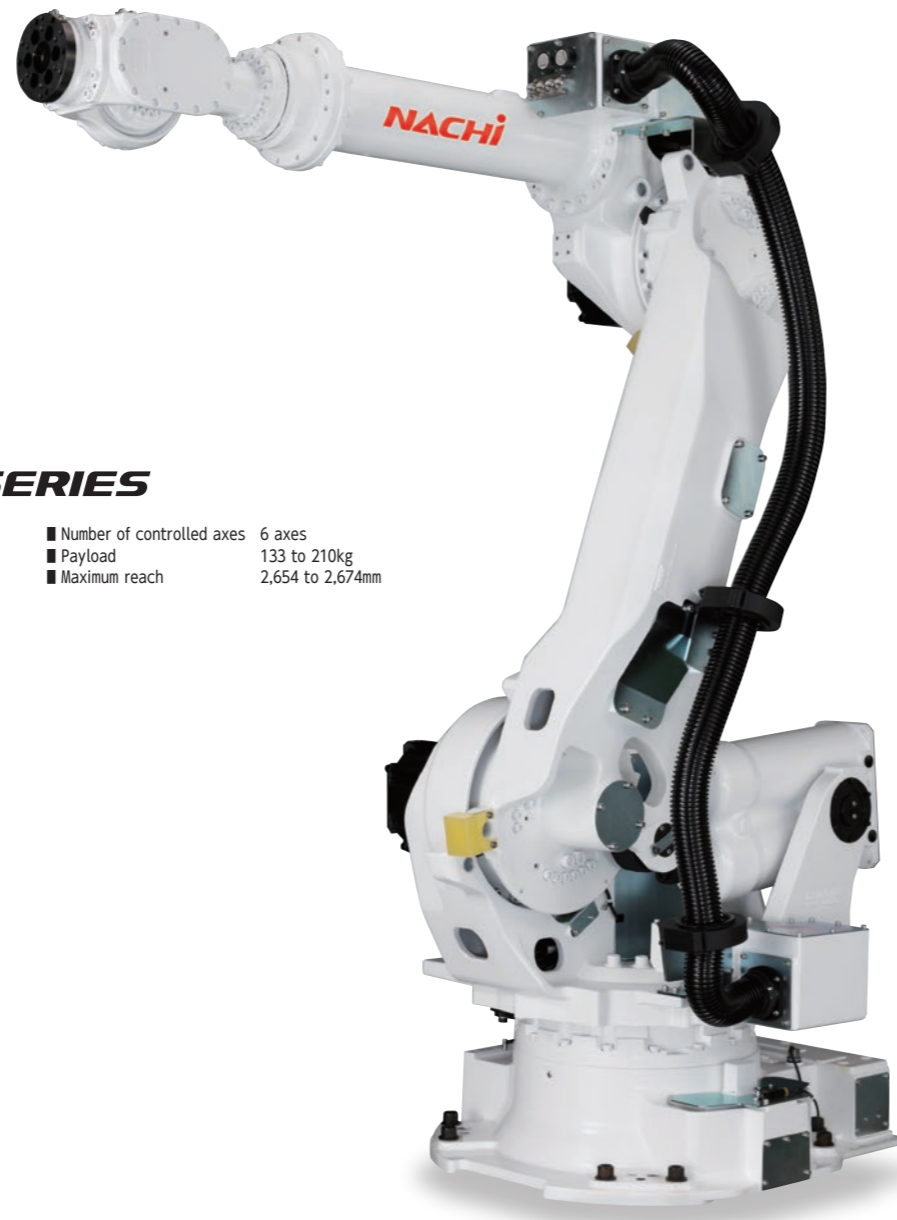

ST-C SERIES

- Number of controlled axes 6 axes
- Payload 133 to 210kg
- Maximum reach 2,654 to 2,674mm



OPTIONS



FLEXhand

Servo hand controlled as an additional axis by the robot controller. Capable of handling many shapes without changing the hand. This is an excellent tool for small-lot multiple item production.



Compact Flex Hand (for MZ)

- The measurement function that automatically detects the dimensions of the workpiece only by the servo hand that is controlled as an additional axis in synchronization with the robot motion enables sensorless selection of workpiece.
- Since the pressure can be set in 1N increments, it is also compatible with fragile workpieces.
- Even if the motor power or power supply goes down, the hand mechanism self-locks to prevent the workpiece from falling.



Force sensor

This function controls the robot by accurately detecting the applied force. This powerful tool makes it possible for robots to do delicate operations at high speed, such as following, pushing, loading (press fitting), detecting position and phase during assembly and production processes.



Compact vision sensor NVsmart

Integrated A1:D58, lighting, and image processing equipment to save space and wiring. Processing speed is also improved 2.5 times compared with the conventional one. It can be configured and monitored on teach pendant and also supports additional control of external cameras. It is possible to recognize mixed workpieces, and supports character recognition, barcode recognition, OCR.

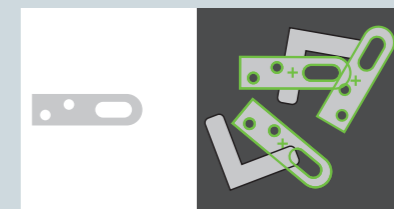

Position posture recognition

Posture can be correctly recognized even when various workpieces are mixed.

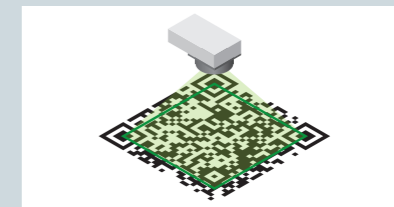

Barcode recognition

Recognizes barcodes/QR codes without additional equipment such as QR Code Scanners.

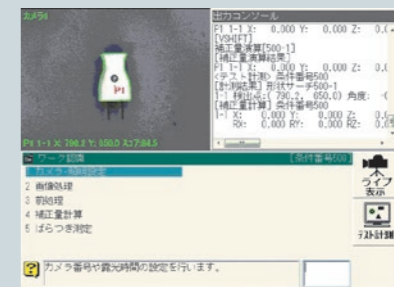

Cooperation with teach pendant

Vision setting and monitoring can be set through robot teach pendant.

NVsmart System Configuration Diagram

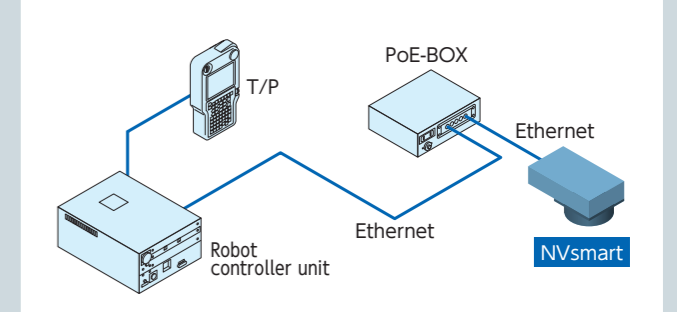

Packaged Product

Connector insertion application

The new visual control application enables high-speed and high-precision insertion of FPC and FFC for various applications such as smartphones and in-vehicle displays.



High-precision and high-speed operation

- Our original visual control enables high-speed, high-precision insertion into the connector.
- Performs real-time scanning and repeats measurements and movements until the target point is reached. Follow-up correction is possible even if the target point deviates during movement.
- Since a force sensor is not used, connector insertion time is greatly reduced.

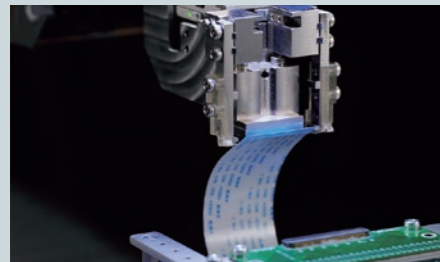

Grip

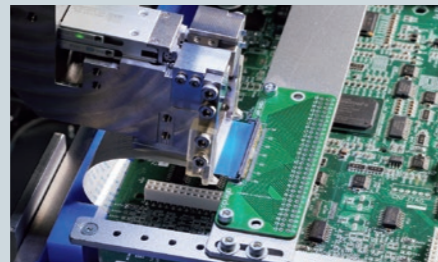

Insert



Inspection

Equipped with traceability function as standard*

- Visual inspection results at the time of insertion and completion are saved as image data.
- Equipped with a QR code reader function as standard, it is possible to manage and record inspection results and link to image data.

* USB port expansion cable (optional) and USB flash drive (Customer Prepared) are required.

System standard kit

- Standard kit for building automated equipment using robots with a payload of 5 to 12 kg.
- Systemize by combining necessary equipment.
- Pre-installed operating screen, I/O settings, and standard robot program.
- Easy installation and relocation with Plug & Play.
- Movable with a hand lifter, so you can use it when and where you want.

System standard kit components

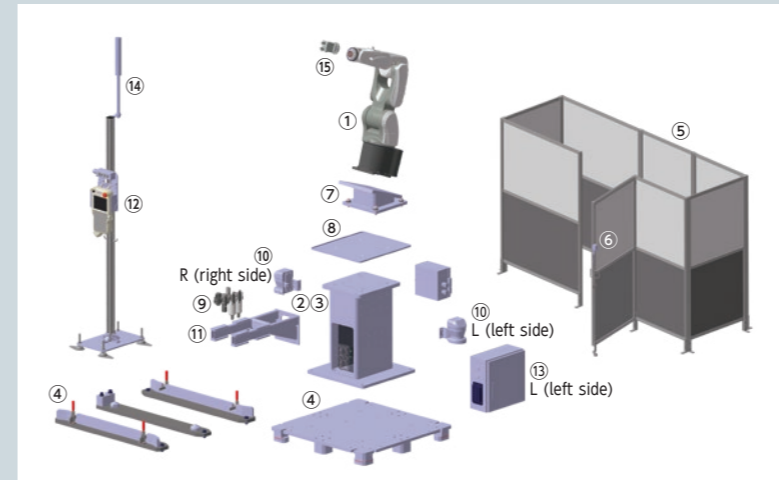

- ① Robot
- ② Robot riser
- ③ Robot clamping parts
- ④ Movable installation unit (movable side module/ fixed base)
- ⑤ Safety fence
- ⑥ Safety fence option
- ⑦ Tilted installation stand
- ⑧ Oil pan

- ⑨ Air pressure conditioning unit
- ⑩ Safety laser scanner
- ⑪ Pallet installation arm
- ⑫ Teach pendant holder stand
- ⑬ Connection box for system controller (installed on the left side in this diagram)/Breaker box
- ⑭ Signal tower
- ⑮ Robot gripper (MZ standard gripper or small flex gripper)



Screw tightening unit STU5

- Automatically correct the relative positions of screws and screw holes in three dimensions using a 3D vision device.
- Automatically corrects the tilt of the screw relative to the screw hole using cameras from two directions.
- Reduces failures related to screw tightening work such as missing screws, diagonal insertion of screws, and floating screws.
- Screw tightening status traceability function and automatic bit exchange device available as options.

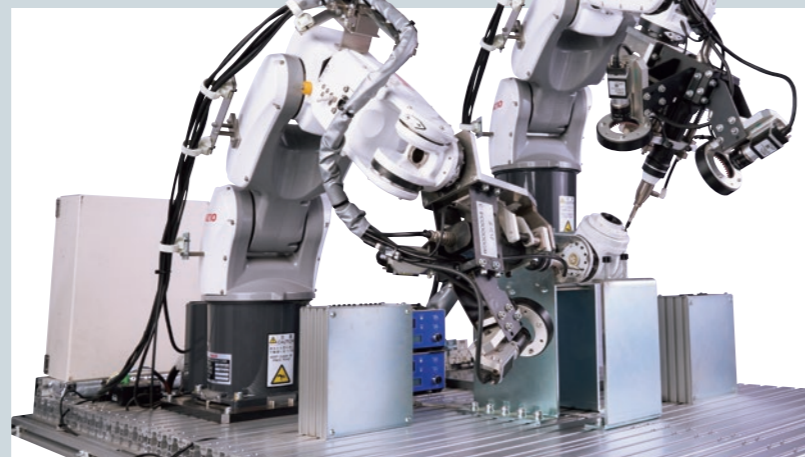
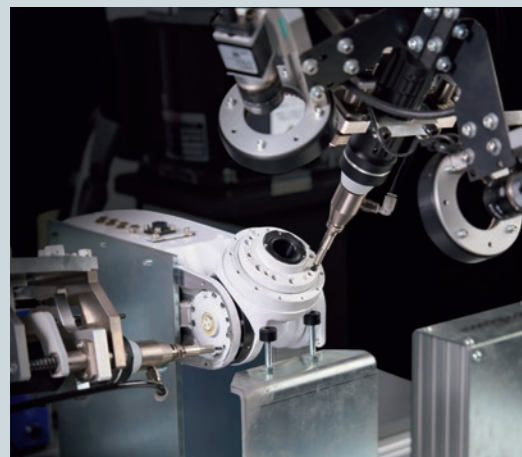

PCB transfer cell

- Realizes many PCB transfer operations existing in PCB production line
- Vacuum pad position is automatically changed according to PCB size. Variable pitch vacuum hand for multiple models realizes variable pitch function without drive source
- MZ12W with unique axis structure for storing PCB in racks in narrow spaces
- MZ-F medium payload series ideal for replacing PCB magazine racks



CONTROLLERS

Introducing the intelligent robot controller based on Windows. Robots and additional axis are easy to operate by using the teach pendant. Vision and force sensors, as well as networks, are managed in one place.



Item	Specifications	
Basic specifications for controller		
Controllable axes	6	
Maximum controllable axes	6	8
Volume	6.0L	12.4L
Weight	5kg	8.9kg
External dimensions (mm)	270(W)×270(D)×82.9(H) Exclude Fan Motor, Switch, Connector, etc.	310(W)×250(D)×160(H) Exclude rubber feet, switches/connectors
Position reader	Absolute encoder	
Programming system	Teaching playback	
Operating panel	-	Mode switch (teach/playback), emergency stop button
Cables between robot and control panel	2m, 5m, 10m, 15m, 20m (connector type) extension (total) 25m	
Additional slot	PCIe x1 slots	PCIe x2 slots
PLC function	Software PLC ISaGRAF 6	
Protection class	IP20 equivalent	
Power supply	Single phase 200-230VAC, 50/60Hz, D grounding, max. leakage 10mA	
Ambient temperature/humidity	0 to 45° C (50/60Hz) 20 to 85% (No dew or frost allowed)	
Safety function	Safety sequence PLd, category 3 (ISO 13849 -1)	
Overseas compliance	Europe: CE, Korea: KCs, North America UL/CSA	
Controller options		
Power voltage converter	Single phase 100 VAC, 50/60 Hz	
External storage	USB Flash Drive (1 GB)	
Additional axes	-	Additional 2 axes
Fieldbus	EtherNet/IP, EtherCAT, Profinet, CC-Link and others. Maximum 2 channels can be installed.	EtherNet/IP, EtherCAT, Profinet, CC-Link and others. Maximum 4 channels can be installed.
Additional input/output signals	Additional I/O board: 32 points/32 points	Additional compact I/O board: Maximum 16/16 point, Additional I/O board: Maximum 64/64 point
Output signals	Additional I/O board: Transistor output	Additional compact I/O board : Relay contact output, Additional I/O board: Transistor output
Analog input/output	-	
Vision sensor	NVsmart	
Conveyor tracking function	Conveyor tracking control	
Palletize function	Palletize and de-palletize	
Robot language	JIS B 8439 SLIM compliant	
Robot monitoring function	-	Position/speed monitoring function: PLd, category 3 (ISO 13849 -1)



Item	Specifications	
Basic specifications for controller		
Controllable axes	6	
Maximum controllable axes	8	
External dimensions (mm)	300(W)×600(D)×530(H) Excluded Casters (50mm), Switches/connectors	580(W)×532(D)×490(H) Excluded Casters (50mm), Switches/connectors
Position reader	Absolute encoder	
Programming system	Teaching playback	
Operating panel	Mode switch (teach/playback), emergency stop button	
Cables between robot and control panel	5m, 10m, 15m, 20m, 25m (connector type) extension (total) 25m	
User interface	User panel : On back	
Additional slot	PCI x2 slots	PCI x3 slots
PLC function	Software PLC ISaGRAF 6	
Protection class	IP54 equivalent	
Power supply	3φ 200-230VAC, 50/60Hz, D grounding, breaker 40A, max. leakage 30mA	
Ambient temperature/humidity	0 to 45° C (50/60Hz) 20 to 85% (No dew or frost allowed)	
Safety function	Safety sequence :PLe, category 4 (ISO 13849 -1)	
Controller options		
Overseas compliance	Europe: CE, Korea: KCs, North America UL/CSA	
Power voltage converter	380/400/420/440/460/480VAC (3φ 50/60Hz) Transformer BOX size: W300×D600×H430 Casters (90mm), Switches/connectors not included Size when controller and transformer BOX are connected: W300×D600×H960 Casters (90mm), Switches/connectors not included	380/400/420/440/460/480VAC (3φ 50/60Hz) Built-in transformer
External storage	USB Flash Drive (1 GB)	
Additional axes	Gun, slider, jig and gripper	
Fieldbus	DeviceNet, CC-Link, CC-Link IE Field and others. Maximum 4 channels can be installed.	
Additional input/output signals	Additional compact I/O board: Maximum 14/10 point, Additional I/O board: Maximum 32/32 point	Additional compact I/O board: Maximum 14/10 point, Additional I/O board: Maximum 64/64 point
Output signals	Relay contact specifications cations 32 point	Relay contact specifications cations 32 point
Analog input/output	2/4 point	
Vision sensor	NVsmart	
Conveyor tracking function	Conveyor tracking control	
Palletize function	Palletize and de-palletize	
Robot language	JIS B 8439 SLIM compliant	
Robot monitoring function	Position/speed monitoring function:PLd, category 3 (ISO 13849 -1)	

CONTROLLERS

Teach pendant

A small and lightweight teach pendant.

Equipped with a high-definition touch panel and has a wide range of optional functions.



Item	Specification	
	CFDq	CFDs/FD18/FD20
Display	5.7 inch VGA color LCD touch panel	
Language	Japanese (Kanji, Hiragana, Katakana, Alphanumeric) English/Chinese/Korean option*: German/Italian/Spanish/Taiwanese	
Enable SW	One-handed enable switch, three positions, (left hand side)	
Operation function	Axis operation key, value input key, selection/function key, motors on key, emergency stop	
External storage interface	USB port	
Cable length	8m, 15m, 20m, 25m, 30m (connector type)	
Protection class	IP65 equivalent	
External dimensions (mm)	163(W)×74.5(D)×353(H)	
Weight	0.9kg	

* Included in the standard specification for CFDs controller

Option Graphic user interface Flex Gui

Freely customize the screen of the teach pendant. It can be used as an operating panel for the entire system including peripheral devices.

FlexGui

- Creation of operating monitor screens tailored to applicable processes and applications.
- Intuitive system operation with touch panel
- The entire system can be controlled by using the software PLC function.
- Abolishing the independent system controller, contributing to space savings and cost reductions.

FlexGui Remote

- Connect a computer to the robot controller
- Remote display and operation of teach pendant (FlexGui) screen

FlexGui Toolbox

- Easily create screens with the editing tool "FlexGui Toolbox"
- Prepare a wide variety of parts (items that make up the screen)

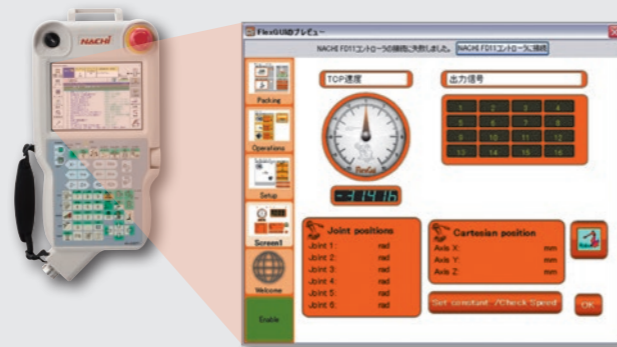

NEW Tablet TP

Tablet TP is a new type of teaching device that uses a commercially available tablet attached to a special holder.

The large, easy-to-read screen provides unprecedented operability.



Item	Specification	
	TBHLDR-0000/TBHLDR-0010	
Compatible robot Controller model	MZ03EL/MZ04/MZ07/MZ10 series/CFDs-0000*1, MZ-F series/CFDs-0000F, MZ01 series/CFDs-0040*1, MZ12 series/CFDs-3000, MZS series/CFDs-0000C	
Compatible tablet specifications *2	Screen size: 10-13 inches, thickness: 10mm or less, weight: 1.1kg or less (see standard specifications for details)	
Number of controlled axes	Standard 6 axes (robot axes only) *External axes are not supported	
Teaching method	Teaching playback	
Number of program selections	9,999 species	
Operating switch	Emergency stop button, +/- button, Select button	
Protection class	IP54 equivalent (excluding tablet PC and USB Type C cable)	
Power supply	DC24V±10% Supplied from TP cable (FD19TP-D04M)	
Ambient temperature	0 to 40°C	
Transport/storage temperature	-25 to 55°C (up to 70°C allowed within one day)	
Ambient humidity	20-85% (No dew, nor frost allowed)	
Elevation	At 1000m or lower sea level	
External dimensions (mm)	224.8(W)×225.6(D)×83.2(H) *Excluding tablet and TP cable.	
Standard mass	775g *Excluding tablet and TP cable.	

*1: Even in the case of CFDs controller, the following robots are not supported, please note. EC series (CFDs-0040/CFDs-2040F), EZ (CFDs-0000)

*2: This may not apply depending on the shape of the tablet. In addition, the weight specifications of compatible tablet is a reference value. Please note that we do not guarantee that the product will not be destroyed or malfunction due to the fall impact.

Easy programming with Drag&Drop

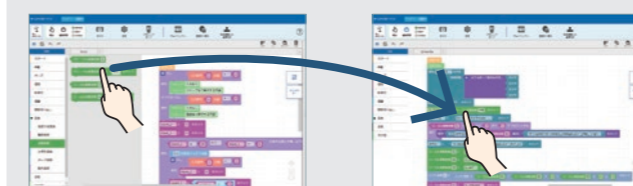

Large screen that is easy to see and press

Large, easy-to-press button

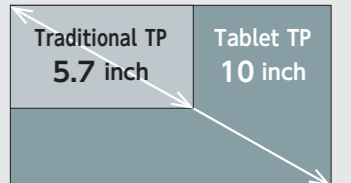

*Tablets will be provided by the customer.

Intuitive operability like a smartphone

Tap the icon



Manipulate graphs directly

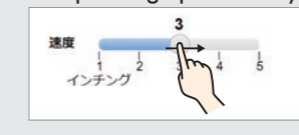

Easy-to-understand guides and tutorials

Guide function

If you touch the part you want to see the explanation, the message will be displayed.

Tutorial function

A video with audio guide explains basic usage.

Customize the way you hold it

By replacing the holder parts, you can freely change between holding it in both hands and holding it in arm. Additionally, the grip angle can be changed according to the operator's preference, allowing a comfortable holding position and reducing fatigue during long hours of teaching work.

Cradle holding type



Both hand



LIST OF SPECIFICATIONS

																
Type		MZ01	MZ03EL	MZ04 (MZ04D)	MZ04E (MZ04DE)	MZ07 (MZ07P)	MZ07L (MZ07LP)			MZ10	MZ07F	MZ07LF	MZ10LF	MZ10F	MZ10SF	
No. of axes		6					6(5)*1				6	6				
Max. working envelope	Arm	J1 Swivel 1	±170°							±170°	±170°					
		J2 Horizontal	-90~+85°	-135~+80°	-145~+90°		-135~+80°		-135~+80°	-135~+80°						
		J7 Swivel 2	-							-	-					
	Wrist	J3 Vertical	-111~+175°	-155~+270°	-125~+280°		-136~+270°	-139~+270°	-136~+270°	-136~+270°	-139~+270°	-139~+270°	-136~+270°	-138~+270°	-136~+270°	
		J4*1 Rotation 2	±145°	±190°		±190° (-)		±190°	±190°	±190°		±190°				
		J5 Bend	±125°	±120°					±120°	±120°	±120°					
Max. speed	Arm	J1 Swivel 1	320°/s	300°/s	480°/s	200°/s	450°/s	300°/s	300°/s	450°/s	300°/s					
		J2 Horizontal	320°/s	230°/s	460°/s	150°/s	380°/s	280°/s	250°/s	380°/s	280°/s	200°/s	240°/s	250°/s		
		J7 Swivel 2	-							-	-					
	Wrist	J3 Vertical	375°/s	360°/s	520°/s	190°/s	520°/s	360°/s	360°/s	520°/s	360°/s	330°/s			360°/s	
		J4*1 Rotation 2	600°/s	550°/s	560°/s		550°/s (-)		450°/s	550°/s		470°/s				
		J5 Bend	600°/s	550°/s	560°/s		550°/s		340°/s	550°/s		470°/s				
Maximum load	Wrist	1kg	3.5kg	4kg		7kg		10kg	7kg		10kg					
	Load capacity on forearm	0.25kg	-							-	-					
Allowable static load torque for wrist	J4*1 Rotation 2	0.9N·m	6N·m	8.86N·m		16.6N·m (-)		17.9N·m	16.9N·m		20N·m					
	J5 Bend	0.9N·m	6N·m	8.86N·m		16.6N·m		17.9N·m	16.9N·m		20N·m					
	J6 Rotation 1	0.78N·m	2.9N·m	4.9N·m		9.4N·m		10.4N·m	9.4N·m		10.4N·m					
Allowable moment of inertia for wrist	J4*1 Rotation 2	0.008kg·m ²	0.12kg·m ²	0.2kg·m ²		0.47kg·m ² (-)		0.47kg·m ²	0.49kg·m ²		0.6kg·m ²					
	J5 Bend	0.008kg·m ²	0.12kg·m ²	0.2kg·m ²		0.47kg·m ²		0.47kg·m ²	0.49kg·m ²		0.6kg·m ²					
	J6 Rotation 1	0.006kg·m ²	0.03kg·m ²	0.07kg·m ²		0.15kg·m ²		0.15kg·m ²	0.15kg·m ²		0.2kg·m ²					
Maximum reach	350mm	1,102mm	541mm		723mm	912mm	723mm	723mm	912mm	1,202mm	912mm	912mm	723mm			
Pose repeatability	±0.02mm	±0.03mm	±0.02mm		±0.02mm	±0.03mm	±0.03mm	±0.015mm	±0.02mm	±0.025mm	±0.02mm					
Ambient temperature*2/ humidity	0 to 40°C/20 to 85% RH (without condensation)	0 to 45°C/20 to 85% RH (without condensation)							0 to 45°C/20 to 85% RH (without condensation)							
Vibration	0.5 G or less							0.5 G or less								
Installation	Floor, wall, inverted, tilted mount			Floor, inverted mount	Floor, wall, inverted, tilted mount				Floor, inverted mount	Floor, wall, inverted, tilted mount*5			Floor, inverted mount			
Ingress protection	IP40 equivalent	IP67 equivalent	IP40 equivalent*3		IP67 equivalent				IP67 equivalent							
Weight	10kg*4	39kg	26kg*4	25kg*4	36kg*4	38kg*4	36kg	41kg	43kg	55kg	54kg	41kg				
Power consumption	0.4kVA							0.4kVA	0.7kVA	0.8kVA	0.8kVA	0.8kVA	0.8kVA			
Supported Controller	CFDs/CFDq	CFDs	CFDs	CFDs	CFDs	CFDs	CFDs	CFDs/CFDq	CFDs/CFDq	CFDs/CFDq	CFDs/CFDq	CFDs/CFDq	CFDs/CFDq			
Working envelope																

* Maximum speeds are maximum values, they will vary depending on the wrist load conditions and operating program.
 *1: For the 5-axis specifications (MZ07P and MZ07LP), the configuration does not have the J4 axis. *2: Using at 1,000 m or lower sea level. Ambient temperature has limitations when allowable altitude is exceeded.
 *3: MZ04 and MZ04E have IP40 equivalence. MZ04D and MZ04DE have IP67 (dust proof and water proof) equivalence.
 4: Wall mount Rear Connection Type: +4kg (MZ04 Series), +6kg (MZ07* Series) / Bottom Connection Type: +6kg (MZ04* Series), +8kg (MZ07* Series), +2.5kg (MZ01)
 *5: Operating range is limited when mounted on a wall or tilted. (Example: #1-axis operating range is ±30° for wall mount)

1 [N·m] = 1/9.8 [kgf·m]

LIST OF SPECIFICATIONS

Type		MZ12	MZ12H	MZ15H	MZ12W	MZ25	MZ35S	MZ35F	MZ50F	MZ70F	MZ50LF	CZ10	
No. of axes		6			6	6	6	6			6	6	
Max. working envelope	Arm	J1 Swivel 1	±170°		±95°	±170°	±170°	±180°			±170°	±170°	
		J2 Horizontal	-160~+90°		+180~-70°	-150~+105°	-150~+105°	-135~+80°			-75~+225°	-75~+225°	
		J3 Vertical	-147~+210°		+210~-147°	-161~+289°	-161~+289°	-143.5~+260°			-77~+227°	-77~+227°	
	Wrist	J4 Rotation 2	±190°		±190°	±190°	±190°	±190°			±180°	±180°	
		J5 Bend	±140°		±135°	±135°	±145°	±145°			±170°	±170°	
		J6 Rotation 1	±360°		±360°	±360°	±360°	±360°			±360°	±360°	
Max. speed	Arm	J1 Swivel 1	260°/s		260°/s	210°/s	210°/s	188°/s	185°/s	180°/s		120°/s	120°/s
		J2 Horizontal	230°/s		230°/s	185°/s	140°/s	180°/s		145°/s	140°/s	120°/s	120°/s
		J3 Vertical	260°/s		260°/s	270°/s	225°/s	195°/s	185°/s	170°/s	180°/s	180°/s	180°/s
	Wrist	J4 Rotation 2	470°/s		470°/s	420°/s	350°/s	280°/s	260°/s	240°/s	260°/s	260°/s	180°/s
		J5 Bend	470°/s		280°/s	280°/s	420°/s	260°/s	310°/s	260°/s	240°/s	260°/s	180°/s
		J6 Rotation 1	700°/s	740°/s	620°/s	620°/s	672°/s	400°/s	420°/s	370°/s	350°/s	370°/s	180°/s
Maximum load	Wrist	12kg		15kg	12kg	25kg	35kg	35kg	50kg	70kg	50kg	10kg	
	Load capacity on forearm*1	-		-	-	-	-	-			-	-	
Allowable static load torque for wrist	J4 Rotation 2	25N·m	26.5N·m	35N·m	55N·m	52N·m	110N·m	165N·m	216N·m	309N·m	216N·m	25.9N·m	
	J5 Bend	25N·m	26.5N·m	35N·m	55N·m	52N·m	110N·m	165N·m	216N·m	309N·m	216N·m	25.9N·m	
	J6 Rotation 1	9.8N·m	12N·m	15N·m	50N·m	32N·m	60N·m	102N·m	147N·m	170N·m	147N·m	5.9N·m	
Allowable moment of inertia for wrist	J4 Rotation 2	0.7kg·m ²	0.9kg·m ²	1.6kg·m ²	3kg·m ²	2.4kg·m ²	5kg·m ²	16kg·m ²	30kg·m ²	30kg·m ²	30kg·m ²	0.75kg·m ²	
	J5 Bend	0.7kg·m ²	0.9kg·m ²	1.6kg·m ²	3kg·m ²	2.4kg·m ²	5kg·m ²	16kg·m ²	30kg·m ²	30kg·m ²	30kg·m ²	0.75kg·m ²	
	J6 Rotation 1	0.2kg·m ²	0.3kg·m ²	0.8kg·m ²	2.6kg·m ²	1.3kg·m ²	1.5kg·m ²	5kg·m ²	12kg·m ²	12kg·m ²	12kg·m ²	0.08kg·m ²	
Maximum reach	1,454mm			1,564mm	1,882mm	1,882mm	2,102mm			2,502mm	1,300mm		
Pose repeatability	±0.04mm			±0.04mm	±0.05mm	±0.05mm	±0.06mm			±0.1mm	±0.1mm		
Ambient temperature*2/ humidity	0 to 45°C/20 to 85% RH (without condensation)						0 to 45°C/20 to 85% RH (without condensation)						
Vibration	0.5 G or less						0.5 G or less						
Installation	Floor, inverted, tilted mount		Floor, inverted mount	Floor, inverted, tilted mount			Floor, inverted, tilted mount	Floor, inverted mount			Floor, inverted mount		
Ingress protection	IP67 equivalent						IP67 equivalent						
Weight	150kg	155kg	155kg	195kg	250kg		250kg	593kg			611kg	61kg	
Power consumption	1.8kVA		1.8kVA	2.0kVA	2.55kVA		2.55kVA	2.17kVA			1kVA		
Supported Controller	CFDs	CFDs	CFDs	CFDs	FD18/FD20		FD18/FD20	FD18/FD20			FD18/FD20	CCZ	
Working envelope													
	1454		1454	1564	1882	1882	2102			2502	1300		

* Maximum speeds are maximum values, they will vary depending on the wrist load conditions and operating program.
 *1: This value changes by placement and load conditions of a wrist.
 *2: Using at 1,000 m or lower sea level. Ambient temperature has limitations when allowable altitude is exceeded.

1[N·m]=1/9.8[kgf·m]

LIST OF SPECIFICATIONS

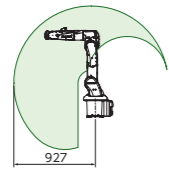
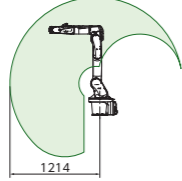
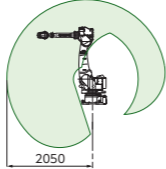
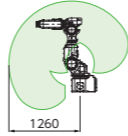
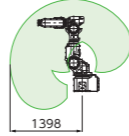
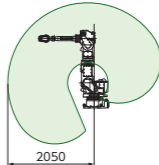
Type	5kg Payload Collaborative Robot	12kg Payload Collaborative Robot	MC35	MC50	MC70	MR20	MR20L	MR35	MR50	ST210TP-01		
No. of axes	6		6			7		7		7		
Max. working envelope	Arm	J1 Swivel 1	±170°		±165°		±180°		±165°		±180°	
		J2 Horizontal	-135~+80°		-135~+80°		-120~+55°		-120~+55°		-35~+120°	
		J7 Swivel 2	-		-		±180°		±190°		(Press arm link) ±65°	
	Wrist	J3 Vertical	-136~+90°	-153~+157°	-146~+260°		-166~+135°		-146~+140°		-96~+210°	
		J4 Rotation 2	±190°	±190°	±360°		±180°		±360°		±360°	
		J5 Bend	±120°	±120°	±125°		±135°		±139°		±120°	
Max. speed	Arm	J1 Swivel 1	270°/s	120°/s	185°/s	180°/s	175°/s	170°/s	180°/s	175°/s	110°/s	
		J2 Horizontal	245°/s	120°/s	180°/s		145°/s		170°/s	175°/s	140°/s	90°/s
		J7 Swivel 2	-	-	-		-		170°/s	130°/s		(Press arm link) 120°/s
	Wrist	J3 Vertical	310°/s	180°/s	190°/s	180°/s	165°/s	170°/s	180°/s	165°/s	95°/s	
		J4 Rotation 2	550°/s	440°/s	305°/s	255°/s	235°/s	250°/s	360°/s	305°/s	255°/s	130°/s
		J5 Bend	550°/s	440°/s	305°/s	255°/s	235°/s	250°/s	360°/s	305°/s	255°/s	130°/s
Maximum load	Wrist	5kg	12kg	35kg	50kg	70kg	20kg		35kg	50kg	80kg	
	Load capacity on forearm*1	-	-	15kg			-		15kg		30kg	
Allowable static load torque for wrist	J4 Rotation 2	16.9N·m	20N·m	160N·m	210N·m	300N·m	80.8N·m	49N·m	160N·m	210N·m	-	
	J5 Bend	16.9N·m	20N·m	160N·m	210N·m	300N·m	80.8N·m	49N·m	160N·m	210N·m	-	
	J6 Rotation 1	9.4N·m	10.4N·m	90N·m	130N·m	150N·m	44.1N·m	23.5N·m	90N·m	130N·m	-	
Allowable moment of inertia for wrist	J4 Rotation 2	0.49kg·m ²	0.60kg·m ²	16kg·m ²	30kg·m ²		6kg·m ²	1.6kg·m ²	16kg·m ²	30kg·m ²	J7 axis rotation 80kg·m ²	
	J5 Bend	0.49kg·m ²	0.60kg·m ²	16kg·m ²	30kg·m ²		6kg·m ²	1.6kg·m ²	16kg·m ²	30kg·m ²		
	J6 Rotation 1	0.15kg·m ²	0.20kg·m ²	5kg·m ²	12kg·m ²		2.3kg·m ²	0.8kg·m ²	5kg·m ²	12kg·m ²		
Maximum reach	927mm	1,214mm	2,050mm			1,260mm	1,398mm	2,050mm		3,106mm		
Pose repeatability	±0.020mm	±0.025mm	±0.07mm			±0.06mm		±0.07mm		±0.3mm		
Ambient temperature*2/ humidity	0 to 40°C/20 to 85% RH (without condensation)		0 to 45°C/20 to 85% RH (without condensation)			0 to 45°C/20 to 85% RH (without condensation)						
Vibration	0.5 G or less											
Installation	Floor	Floor, inverted mount	Floor mount (OP: inverted, wall, tilted)			Floor, inverted mount		Floor mount(OP: inverted, wall, tilted)		Shelf mount (installed at 20° angle)		
Ingress protection	IP67 equivalent		Wrist: IP67 equivalent, main body: IP54 equivalent (OP: IP65/67 equivalent)			IP65 equivalent		IP67 equivalent		-		
Weight	53kg	66kg	640kg			230kg		745kg		1,650kg		
Power consumption	0.8kVA		5kVA			1kVA		4.1kVA		7kVA		
Supported Controller	CFDs	CFDs	FD18/FD20	FD18/FD20	FD18/FD20	FD18/FD20	FD18/FD20	FD18/FD20	FD18/FD20	FD18/FD20		
Working envelope												

* Maximum speeds are maximum values, they will vary depending on the wrist load conditions and operating program.
 *1: This value changes by placement and load conditions of a wrist.
 *2: Using at 1,000 m or lower sea level. Ambient temperature has limitations when allowable altitude is exceeded.



1[N·m]=1/9.8[kgf·m]

LIST OF SPECIFICATIONS

						
Type		EC06-5020-01	EC06-6020-01	EC06-7020-01	EC10-8020-01	EC10-8030-01
No. of axes	4					
Max. working envelope	J1 Swivel 1	±140°			±132°	
	J2 Swivel 2	±150°			±150°	
	J3 Vertical	200mm			200mm	300mm
	J4 Rotation	±360°			±360°	
Max. speed	J1 Swivel 1	420° /s			340° /s	
	J2 Swivel 2	720° /s			630° /s	
	J3 Vertical	1,100mm/s			1,100mm/s	
	J4 Rotation	2660° /s			2,700° /s	
Maximum Payload	6kg (3kg rated)			10kg (rated 5kg, conditional 12kg)		
Allowable moment of inertia for wrist	J4 Rotation	0.05kg·m ² (0.01kg·m ² rated)			0.02kg·m ²	
Maximum reach		500mm	600mm	700mm	800mm	
Pose repeatability	±0.02mm					±0.025mm
Ambient temperature*1/ humidity	0 to 40°C/20 to 80% RH (without condensation)			5 to 40°C/20 to 80% RH (without condensation)		
Vibration	0.5 G or less (4.9m/s ²)			0.5 G or less		
Installation	Floor mount					
Ingress protection	IP20			IP20 equivalent		
Weight	17kg	17kg	18kg	41kg		
Power consumption	0.5kVA			0.8kVA		
Supported Controller	CFDs	CFDs	CFDs	CFDs		
Working envelope						

* Maximum speeds are maximum values, they will vary depending on the wrist load conditions and operating program.
*1: Using at 1,000 m or lower sea level. Ambient temperature has limitations when allowable altitude is exceeded.

1 [N·m] = 1/9.8 [kgf·m]

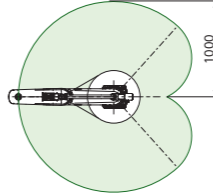
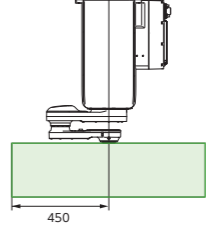
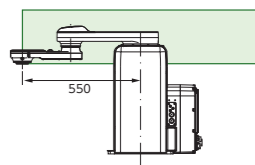
						
Type		EC10-A020-01	EC10-A030-01	EZ03V4-04	EZ03F4-04	
No. of axes	4					
Max. working envelope*1	J1 Swivel 1	±132°			Vertical: 250/150mm*3	
	J2 Swivel 2	±150°			Swivel 1: ±170°	
	J3 Vertical	200mm	300mm	Swivel 2: ±180°	Swivel 2: ±145°	
	J4 Rotation	±360°			±360°	
Max. speed*1	J1 Swivel 1	300° /s			Vertical: 1,400/1,200mm/s*3	
	J2 Swivel 2	620° /s			Swivel 1: 450° /s	
	J3 Vertical	1,100mm/s			Swivel 2: 720° /s	
	J4 Rotation	2,700° /s			2,400° /s	
Maximum Payload	10kg (rated 5kg, conditional 12kg)			3kg (2kg rated)		
Allowable moment of inertia for wrist	J4 Rotation	0.02kg·m ²			0.05kg·m ²	
Maximum reach		1,000mm		450mm	550mm	
Pose repeatability	±0.025mm					±0.014mm
Ambient temperature*2/ humidity	5 to 40°C/20 to 80% RH (without condensation)			0 to 45°C/20 to 85% RH (without condensation)		
Vibration	0.5 G or less			0.5 G or less (4.9m/s ²)		
Installation	Floor mount			Inverted mount	Floor mount	
Ingress protection	IP20 equivalent			IP20		
Weight	44kg			40kg	41kg	
Power consumption	0.8kVA			0.6kVA		
Supported Controller	CFDs			CFDs	CFDs	
Working envelope						

* Maximum speeds are maximum values, they will vary depending on the wrist load conditions and operating program.

*1: EZ03V4-04 and EZ03F4-04 have different motion range. J1: up/down, J2: swivel 1, J3: swivel 2.

*2: Using at 1,000 m or lower sea level. Ambient temperature has limitations when allowable altitude is exceeded.

*3: There are two types of maximum operating envelopes: 250 mm and 150 mm. The 250 mm has a maximum speed of 1,400 mm/s. The 150 mm has a maximum speed of 1,200 mm/s.

LIST OF SPECIFICATIONS



Type		MC280L	MC350	MC400L	MC600	MC700	MC1000DL	SC700DL	
No. of axes		6				6			
Max. working envelope	Arm	J1 Swivel 1	±180°				±180°	±160°	±160°
		J2 Horizontal	-100~+40°		-105~+60°		-105~+60°	-85~+45°	-85~+45°
		J7 Swivel 2	-						
	Wrist	J3 Vertical	-147~+130°	-180~+130°	-130~+30°	-140~+30°	-140~+30°	-90~+45°	-90~+40°
		J4 Rotation 2	±360°		±210°		±210°	-9.7~+90° (+9.7°)*4	-10~+90°
		J5 Bend	±125°		±120°		±120°	±125°*5	±125°
Max. speed	Arm	J6 Rotation 1	±360°		±360°*1		±360°*1	±9.7°	±10°
		J1 Swivel 1	105°/s		90°/s		80°/s	45°/s	45°/s
		J2 Horizontal	105°/s	95°/s	90°/s		80°/s	40°/s	30°/s
	Wrist	J3 Vertical	95°/s		90°/s		80°/s	40°/s	30°/s
		J4 Rotation 2	120°/s	110°/s		100°/s		20°/s*6	30°/s
		J5 Bend	120°/s	110°/s		100°/s		65°/s	50°/s
Maximum load	Wrist	280kg	350kg	400kg	600kg	700kg	1,000kg	700kg	
	Load capacity on forearm*2	25kg	50kg				25kg	-	-
Allowable static load torque for wrist	J4 Rotation 2	1,921N·m	2,750N·m	3,450N·m		3,450N·m	21,000N·m	13,800N·m	
	J5 Bend	1,921N·m	2,750N·m	3,450N·m		3,450N·m	-	3,920N·m	
	J6 Rotation 1	988N·m	1,235N·m	1,725N·m		1,725N·m	4,410N·m	2,940N·m	
Allowable moment of inertia for wrist	J4 Rotation 2	400kg·m ²		600kg·m ²		600kg·m ²	5,200kg·m ²	3,000kg·m ²	
	J5 Bend	400kg·m ²		600kg·m ²		600kg·m ²	4,000kg·m ²	1,800kg·m ²	
	J6 Rotation 1	250kg·m ²		400kg·m ²		400kg·m ²	1,740kg·m ²	1,000kg·m ²	
Maximum reach	3,101mm	2,771mm	3,756mm	2,890mm	2,890mm	3,972mm	3,972mm		
Pose repeatability	±0.09mm				±0.09mm				
Ambient temperature*3/ humidity	0 to 45°C/20 to 85% RH (without condensation)				0 to 45°C/20 to 85% RH (without condensation)				
Vibration	0.5 G or less				0.5 G or less				
Installation	Floor mount				Floor mount				
Ingress protection	-				-				
Weight	1,660kg	1,620kg	3,400kg	3,300kg	3,320kg	9,000kg	7,000kg		
Power consumption	9kVA	8.6kVA	19.3kVA		9.3kVA	19kVA	7kVA		
Supported Controller	FD20	FD20	FD20	FD20	FD20	FD11/FD20	FD20		
Working envelope									

*1: The initial settings are ±210°. When passing cable through the hollow part of the 6th axis, use a range of ±210°. When a cable is not passed through, the operating envelope can be extended to a maximum of ±360°, depending on the usage conditions.
 *2: This value changes by placement and load conditions of a wrist.
 *3: Using at 1,000 m or lower sea level. Ambient temperature has limitations when allowable altitude is exceeded.

*4: Max motion range of axis 4 varies due to the wrist payload weight. Wrist load 300 kg < -9.7°~+90°, Wrist load 300 kg ≥: -9.7°~+9.7°
 *5: In order to make axis 5 move, axis 4 must be in ±4° from ground level when payload is installed on the wrist.
 *6: Axis 4 speed achieves to this value when wrist payload is less than 300 kg and motion range is enough wide.



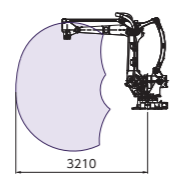
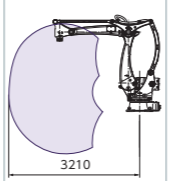
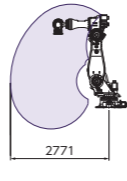
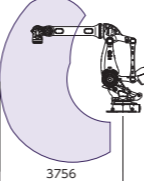

1 [N·m] = 1/9.8 [kgf·m]

LIST OF SPECIFICATIONS

									
Type		LP130-01	LP130F	LP180-01	LP210	High-speed palletizing	MC470P	MC500P	
No. of axes		4					6	5	
Max. working envelope	Arm	J1 Swivel 1	±180°				±180°	±180°	
		J2 Horizontal	-95~+41°	-94.5~+40.7°	-95~+41°	-95~+45°	-100~+40°	-105~+60°	
		J7 Swivel 2	-						
	Wrist	J3 Vertical	-117~+17°	-116.9~+17.2°	-117~+17°	-117.5~+17.5°	-180~+35°	-130~+30°	
		J4 Rotation 2	±360°				±360°*1	-	
		J5 Bend	-				±125°*1	±120°	
Max. speed	Arm	J1 Swivel 1	130°/s	145°/s	115°/s	105°/s	140°/s	105°/s	90°/s
		J2 Horizontal	115°/s		100°/s		125°/s	95°/s	90°/s
		J7 Swivel 2	-						
	Wrist	J3 Vertical	115°/s		105°/s	100°/s	130°/s	95°/s	90°/s
		J4 Rotation 2	400°/s	535°/s	360°/s	300°/s	400°/s	110°/s	-
		J5 Bend	-				110°/s	110°/s	
Maximum load	Wrist	130kg		180kg	210kg	180kg	470kg	500kg	
	Load capacity on forearm*2	25kg				30kg	25kg		
Allowable static load torque for wrist	J4 Rotation 2	-				2,750N·m	-		
	J5 Bend	-				2,750N·m	3,450N·m		
	J6 Rotation 1	-				0N·m	1,725N·m		
Allowable moment of inertia for wrist	J4 Rotation 2	50kg·m ²		69kg·m ²	100kg·m ²	69kg·m ²	400kg·m ²	-	
	J5 Bend	-				400kg·m ²	600kg·m ²		
	J6 Rotation 1	-				250kg·m ²	400kg·m ²		
Maximum reach	3,210mm				2,771mm	3,756mm			
Pose repeatability	±0.09mm								
Ambient temperature*3/ humidity	0 to 45°C/20 to 85% RH (without condensation)								
Vibration	0.5 G or less								
Installation	Floor mount								
Ingress protection	IP50 equivalent	-	IP50 equivalent		-	-			
Weight	1,150kg				1,620kg	3,350kg			
Power consumption	6.2kVA				8.6kVA	9.7kVA			
Supported Controller	FD20	FD20	FD20	FD20	FD20	FD20	FD20		
Working envelope									
	3210		3210		2771	3756			

*1: Software limits the downward vertical range of axis 5 to ±5°. Axis 4 can move ±360° and axis 5 can move ±125° only when the encoder correction screen or software limit settings screen is open.
 *2: This value changes by placement and load conditions of a wrist.
 *3: Using at 1,000 m or lower sea level. Ambient temperature has limitations when allowable altitude is exceeded.

1 [N·m] = 1/9.8 [kgf·m]

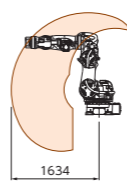
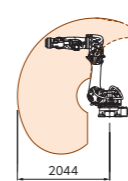
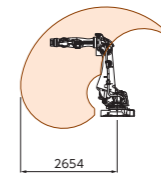
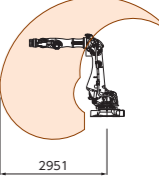
									
Type*1		100kg payload, super-compact hollow wrist	100kg payload, compact hollow wrist	100kg payload, hollow wrist	133kg payload, hollow wrist	133kg payload, hollow wrist	133kg payload, long-arm hollow wrist		
No. of axes		6							
Max. working envelope	Arm	J1 Swivel 1	±180°						
		J2 Horizontal	-120~+60°		-80~+60°				
		J7 Swivel 2	-						
	Wrist	J3 Vertical	-125~+90°	-151~+90°	-146.5~+150°		-133.4~+150°		
		J4 Rotation 2	±210°						
		J5 Bend	±125°						
Max. speed	Arm	J1 Swivel 1	136°/s		125°/s	120°/s	115°/s		
		J2 Horizontal	115°/s		110°/s	105°/s			
		J7 Swivel 2	-						
	Wrist	J3 Vertical	160°/s		121°/s	118°/s	113°/s		
		J4 Rotation 2	210°/s	225°/s	210°/s				
		J5 Bend	175°/s						
Maximum load	Wrist	100kg		133kg					
	Load capacity on forearm*2	20kg							
Allowable static load torque for wrist	J4 Rotation 2	830N·m	650N·m	830N·m					
	J5 Bend	830N·m	650N·m	830N·m					
	J6 Rotation 1	441N·m	315N·m	441N·m					
Allowable moment of inertia for wrist	J4 Rotation 2	85kg·m ²							
	J5 Bend	85kg·m ²							
	J6 Rotation 1	45kg·m ²							
Maximum reach	1,634mm	2,044mm	2,654mm		2,951mm				
Pose repeatability	±0.06mm								
Ambient temperature*3/ humidity	0 to 45°C/20 to 85% RH (without condensation)								
Vibration	0.5 G or less								
Installation	Floor mount								
Ingress protection	IP54 equivalent								
Weight	690kg	750kg	1,040kg		1,070kg				
Power consumption	7kVA								
Supported Controller	FD18/FD20	FD18/FD20	FD18/FD20	FD18/FD20	FD18/FD20	FD18/FD20			
Working envelope									
	1634		2044		2654	2951			

*1: Robot model: SRA100H - 100 kg payload, hollow wrist. Please contact us for details.
 *2: This value changes by placement and load conditions of a wrist.
 *3: Using at 1,000 m or lower sea level. Ambient temperature has limitations when allowable altitude is exceeded.

1 [N·m] = 1/9.8 [kgf·m]

LIST OF SPECIFICATIONS

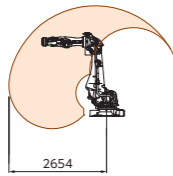
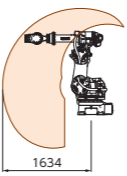
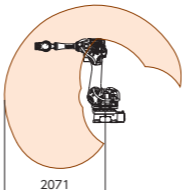
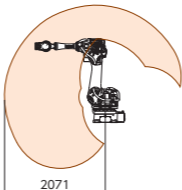
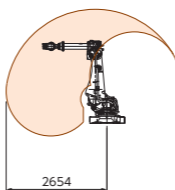
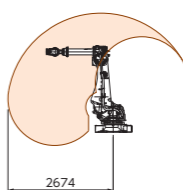
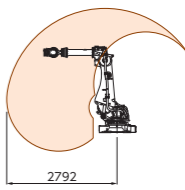
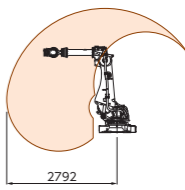
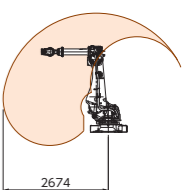
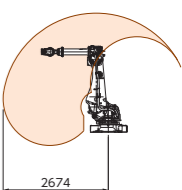
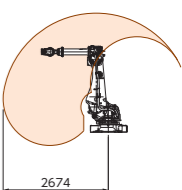
Type*1		166kg payload, hollow wrist	210kg payload, hollow wrist	100kg payload, super-compact	100kg payload, compact	100kg payload*4	166kg payload*4	210kg payload*4	240kg payload	250kg payload	300kg payload
No. of axes		6				6	6				6
Max. working envelope	J1 Swivel 1	±180°		±180°	±180°	±180°		±180°		±180°	
	J2 Horizontal	-80~+60°		-120~+60°	-120~+60°	-80~+60°		-80~+60°		-80~+60°	
	J7 Swivel 2	-		-	-	-		-		-	
	J3 Vertical	-146.5~+150°		-125~+90°	-150~+180°	-146.5~+150°		-146.5~+150°		-140~+150°	-146.5~+150°
	J4 Rotation 2	±210°		±360°	±360°	±360 (±210)°		±360 (±210)°		±360°	±360°
	J5 Bend	±125°		±135°	±135°	±135 (±120)°		±135 (±120)°	±130 (±120)°	±130°	
Max. speed	J6 Rotation 1	±210°		±360°	±360°	±360 (±205)°		±360 (±205)°		±360°	±360°
	J1 Swivel 1	120° /s	115° /s	136° /s	136° /s	136° /s	125° /s	115° /s	105° /s	100° /s	105° /s
	J2 Horizontal	110° /s	105° /s	115° /s	110° /s	135° /s	115° /s	105° /s	90° /s		90° /s
	J7 Swivel 2	-		-	-	-		-		-	
	J3 Vertical	115° /s	113° /s	160° /s	130° /s	135° /s	121° /s	113° /s	100° /s	95° /s	90° /s
	J4 Rotation 2	175° /s	130° /s	240° /s	240° /s	240° /s	180° /s	140° /s	130° /s	125° /s	120° /s
Maximum load	J5 Bend	171° /s	130° /s	233° /s	233° /s	233° /s	173° /s	133° /s	125° /s		120° /s
	J6 Rotation 1	280° /s	205° /s	351° /s	351° /s	351° /s	260° /s	200° /s	195° /s	190° /s	200° /s
Allowable static load torque for wrist	Wrist	166kg	210kg	100kg	100kg	100kg	166kg	210kg	240kg	250kg	300kg
	Load capacity on forearm*2	20kg		25kg/Max.45kg	25kg/Max.45kg	45kg/Max.90kg (15kg/Max.60kg)			20kg/Max.45kg		25kg/Max.50kg
Allowable moment of inertia for wrist	J4 Rotation 2	960N·m	1337N·m	580N·m	580N·m	580N·m	951N·m	1,337N·m		1,830N·m	
	J5 Bend	960N·m	1337N·m	580N·m	580N·m	580N·m	951N·m	1,337N·m		1,830N·m	
	J6 Rotation 1	520N·m	720N·m	290N·m	290N·m	290N·m	490N·m	720N·m		930N·m	
Maximum reach	J4 Rotation 2	100kg·m ²	200kg·m ²	45kg·m ²	45kg·m ²	60kg·m ²	88.9kg·m ²	141.1kg·m ²		225.4kg·m ²	330kg·m ²
	J5 Bend	100kg·m ²	200kg·m ²	45kg·m ²	45kg·m ²	60kg·m ²	88.9kg·m ²	141.1kg·m ²		225.4kg·m ²	330kg·m ²
	J6 Rotation 1	50kg·m ²	155kg·m ²	22.7kg·m ²	22.7kg·m ²	30kg·m ²	45kg·m ²	79kg·m ²		196kg·m ²	240kg·m ²
Pose repeatability	±0.06mm				±0.06mm				±0.1mm		
Ambient temperature*3/ humidity	0 to 45°C/20 to 85% RH (without condensation)					0 to 45°C/20 to 85% RH (without condensation)					
Vibration	0.5 G or less					0.5 G or less					
Installation	Floor mount					Floor mount					
Ingress protection	IP54 equivalent		Wrist has IP67 and main body has IP54 equivalent			Wrist has IP67 and main body has IP54 equivalent					
Weight	1,100kg		670kg	690kg	960 (1,060)kg		990 (1,090)kg	990kg	1,030kg	1,170kg	
Power consumption	7kVA					7kVA					
Supported Controller	FD18/FD20	FD18/FD20	FD18/FD20	FD18/FD20	FD18/FD20	FD18/FD20	FD18/FD20	FD18/FD20	FD18/FD20	FD18/FD20	FD20
Working envelope											

*1: Robot model: SRA166H - 166 kg payload, hollow wrist. Please contact us for details.
 *2: This value changes by placement and load conditions of a wrist.
 *3: Using at 1,000 m or lower sea level. Ambient temperature has limitations when allowable altitude is exceeded.
 *4: Equipped with a cable support on the arm, suitable for spot welding.

1 [N·m] = 1/9.8 [kgf·m]

LIST OF SPECIFICATIONS

Type*1		120kg payload, extra-long arm	133kg payload, long arm	166kg payload, long arm	210kg payload, long arm	240kg payload, long arm	166kg payload, shelf-mounted*4	166kg payload, shelf-mounted long arm	210kg payload, shelf-mounted*4	166kg payload, shelf-mounted hollow wrist	210kg payload, shelf-mounted hollow wrist	210kg payload, inverted mount		
No. of axes		6				6		6			6		6	
Max. working envelope	Arm	J1 Swivel 1	±180°				±180°		±180°			±180°		±165°
		J2 Horizontal	-80~+60°				-80~+60°		-65~+120°			-65~+120°		-80~+60°
		J7 Swivel 2	-				-		-			-		-
	Wrist	J3 Vertical	-127.7~+150°	-133.4~+150°		-132.4~+150°	-135.8~+150°	-106~+210°	-90~+210°	-106~+210°	-112~+210°		-146.5~+150°	
		J4 Rotation 2	±360°				±360°		±360 (±210)°	±360°	±360 (±210)°	±210°		±360°
		J5 Bend	±135°				±130°		±135 (±120)°	±135°	±130 (±120)°	±125°		±130°
Max. speed	Arm	J4 Rotation 2	±360°				±360°		±360 (±205)°			±210°		±360°
		J5 Bend	±135°				±130°		±135 (±120)°			±125°		±130°
		J6 Rotation 1	±360°				±360°		±360 (±205)°			±210°		±360°
	Wrist	J1 Swivel 1	115° /s	125° /s	115° /s	100° /s	110° /s	105° /s	100° /s	120° /s	115° /s	113° /s	115° /s	
		J2 Horizontal	105° /s	115° /s	105° /s	90° /s	110° /s	90° /s		110° /s	105° /s	105° /s	105° /s	
		J3 Vertical	113° /s	121° /s	113° /s	95° /s	115° /s		100° /s	115° /s	113° /s	113° /s	113° /s	
Wrist	J4 Rotation 2	140° /s				125° /s	180° /s	140° /s	140° /s	175° /s	130° /s	140° /s		
	J5 Bend	173° /s				125° /s	173° /s		133° /s	171° /s	130° /s	133° /s		
	J6 Rotation 1	260° /s				190° /s	260° /s		200° /s	280° /s	205° /s	200° /s		
Maximum load	Wrist	120kg	133kg	166kg	210kg	240kg	166kg			210kg	166kg	210kg	210kg	
	Load capacity on forearm*2	45kg/Max.90kg				20kg		45kg/Max.90kg (15kg/Max.60kg)			20kg		45kg/Max.90kg	
Allowable static load torque for wrist	J4 Rotation 2	687N·m	800N·m	951N·m	1,000N·m	1,140N·m	951N·m			1,337N·m	960N·m	1,337N·m	1,337N·m	
	J5 Bend	687N·m	800N·m	951N·m	1,000N·m	1,140N·m	951N·m			1,337N·m	960N·m	1,337N·m	1,337N·m	
	J6 Rotation 1	353N·m	400N·m	490N·m	720N·m	720N·m	490N·m			720N·m	520N·m	720N·m	720N·m	
Allowable moment of inertia for wrist	J4 Rotation 2	60kg·m ²	76kg·m ²	88.9kg·m ²	141.1kg·m ²		88.9kg·m ²			141.1kg·m ²	100kg·m ²	200kg·m ²	141.1kg·m ²	
	J5 Bend	60kg·m ²	76kg·m ²	88.9kg·m ²	141.1kg·m ²		88.9kg·m ²			141.1kg·m ²	100kg·m ²	200kg·m ²	141.1kg·m ²	
	J6 Rotation 1	30kg·m ²	38kg·m ²	45kg·m ²	79kg·m ²		45kg·m ²			79kg·m ²	50kg·m ²	155kg·m ²	79kg·m ²	
Maximum reach	3,099mm	2,951mm		3,000mm	2,901mm	3,086mm	3,383mm	3,106mm	3,087mm		2,674mm			
Pose repeatability	±0.06mm				±0.08mm		±0.08mm			±0.08mm		±0.15mm		
Ambient temperature*3/ humidity	0 to 45°C/20 to 85% RH (without condensation)						0 to 45°C/20 to 85% RH (without condensation)							
Vibration	0.5 G or less						0.5 G or less							
Installation	Floor mount						Shelf mount					Inverted mount		
Ingress protection	Wrist has IP67 and main body has IP54 equivalent						Wrist has IP67 and main body has IP54 equivalent			IP54 equivalent		Wrist has IP67 and main body has IP54 equivalent		
Weight	985kg	980kg		1,050kg		1,210 (1,310)kg	1,240kg	1,250 (1,350)kg	1,160kg		990kg			
Power consumption	7kVA						7kVA							
Supported Controller	FD18/FD20	FD18/FD20	FD18/FD20	FD18/FD20		FD18/FD20	FD18/FD20	FD18/FD20	FD18/FD20	FD18/FD20	FD18/FD20	FD18/FD20		
Working envelope														

*1: Robot model: SRA120EL - 120 kg payload, extra-long arm. Please contact us for details.
 *2: This value changes by placement and load conditions of a wrist.
 *3: Using at 1,000 m or lower sea level. Ambient temperature has limitations when allowable altitude is exceeded.
 *4: Equipped with a cable support on the arm, suitable for spot welding.

1 [N·m] = 1/9.8 [kgf·m]

LIST OF SPECIFICATIONS



Type		ST133CF	ST166CF	ST210CF
No. of axes		6		
Max. working envelope	Arm	J1 Swivel 1	±165°	
		J2 Horizontal	-80~+60°	
		J7 Swivel 2	-	
	Wrist	J3 Vertical	-137~+150°	
		J4 Rotation 2	±360°	
		J5 Bend	±135°	±130°
Max. speed	Arm	J1 Swivel 1	130° /s	110° /s
		J2 Horizontal	130° /s	110° /s
		J7 Swivel 2	-	-
	Wrist	J3 Vertical	130° /s	110° /s
		J4 Rotation 2	230° /s	170° /s
		J6 Rotation 1	305° /s	260° /s
Maximum load	Wrist	133kg	166kg	210kg
	Load capacity on forearm*1	70kg		
Allowable static load torque for wrist	J4 Rotation 2	745N·m	951N·m	1,337N·m
	J5 Bend	745N·m	951N·m	1,337N·m
	J6 Rotation 1	411N·m	490N·m	720N·m
Allowable moment of inertia for wrist	J4 Rotation 2	60.9kg·m ²	88.9kg·m ²	141.1kg·m ²
	J5 Bend	60.9kg·m ²	88.9kg·m ²	141.1kg·m ²
	J6 Rotation 1	30.2kg·m ²	45kg·m ²	79kg·m ²
Maximum reach	2,654mm		2,674mm	
Pose repeatability	±0.06mm			
Ambient temperature*2/ humidity	10 to 45°C/20 to 85% RH (without condensation)			
Vibration	0.5 G or less			
Installation	Floor mount			
Ingress protection	-			
Weight	1,120kg	-	1,160kg	
Power consumption	4.2kVA			
Clean rating*3	Class 6			
Supported Controller	FD20	FD20	FD20	
Working envelope				

*1: This value changes by placement and load conditions of a wrist.
 *2: Using at 1,000 m or lower sea level. Ambient temperature has limitations when allowable altitude is exceeded.
 *3: Clean rating complies with ISO 14644-1

1 [N·m] = 1/9.8 [kgf·m]

SUPPORT SOFTWARE/FEATURES

Easier to use from introduction, to maintenance, various functions such as PC software and software PLC can be programmed and simulations are prepared.

FD on Desk II (Programming PC software)

Simulation and offline programming product for NACHI robots

- FD on Desk II Pro **Options**
- FD on Desk II Regular **Options**
- FD on Desk II Light **Standard** *CFD controller only

Grade	Pro		Regular		Light	Trial version (Demo Licence)
Type No.	FDONDESK2-PRO	FDONDESK2-PRO-D	FDONDESK2-REG	FDONDESK2-REG-D	-	-
Licence certification	Licence file	USB dongle	Licence file	USB dongle	Actual Robot Controller required	ASK
CFD	Offline mode	○	○	○	○	△
	Monitor mode	○	○	○	○	×
	View mode	○	○	○	○	×
FD	Offline mode	○	○	○	△	△
	Monitor mode	○	○	○	△	×
	View mode	○	○	○	△	×
Program generation function from CAD	○	○	×	×	×	×
Multiple controller operation	○	○	×	×	×	×
Save shape file	○	○	○	○	○	×

○ : Usableness
 △ : Enable to use in operator level BEGINNER. (Applied to MZ, ES and EZ)
 × : Unusableness

FD on Desk III (Programming PC software) **Options**

PC software that makes it easy and smooth for robot applications with programming and simulation functions

Compatible controller: FD/CFD/CFDs/CFDq/FD18/FD20

- Supports reading of large-scale files such as peripheral devices.
- Visual programming

```

    スケジュール
    Move Variable Control Timer Others
    MZ12-01 - Test1
    Move PTP P0
    Move PTP P1
    Move PTP P2
    Move PTP P3
    Move PTP P4
    Move PTP P5
    Delay 1
    Set Out[0] off
    Move CP P6
    Delay 1
    Set Out[0] on
    Move PTP P7
    Move PTP P8
    Move PTP P9
    Move PTP P10
    # Wait EOC action
    Wait Signal 0 On
    Move PTP P11
    Assign V[0] = 1
    Move PTP P12
    Move PTP P13
    Move PTP P14
    # Execute Picking
    Move PTP P15
    Move PTP P16
    
```

- High performance interference surveillance, video output function, etc.

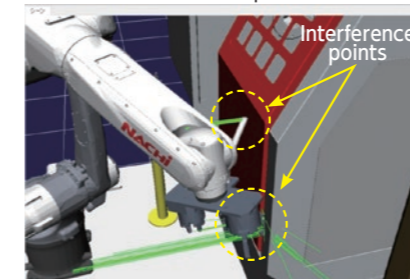

User task functions **Standard**

Possible to program processes in parallel with robot operations

- Time consuming calculations and robot operations are processed in parallel to reduce cycle times
- Various statuses are shown on the screen on the teach pendant

Robot Monitoring Unit RMU **Options**

- Safety control unit monitors robot conditions (position and speed)
- Possible to reduce costs and space
- Facilities are safer because the positions and speeds of robots are monitored

→Limit working envelope of robot
 →Minimize size of safety fences

Working envelope of robot and safety fence

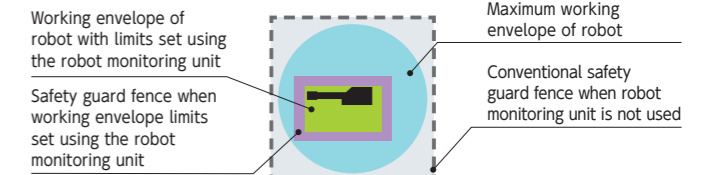

FD-ST easy **Options**

PC software that can teach robot operation programs and simulate operation program on a PC.

- Automatic path generation function specifies edges on the workpiece and automatically generate teaching points for robot to work with.
- Provides an advanced 3D Viewer for importing complex data, viewing scene graphs, and drawing in high definition



Software PLC **Standard**

Incorporated PLC functionality into robot control software

- Eliminates the necessity of external PLC and reduces equipment costs
- Programming is also possible on teach pendant

OpenNR-IF **Options**

Users can create their own application software to connect to the FD controller and external devices (cameras, etc.).

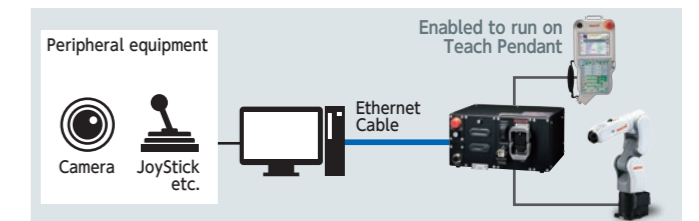

Monitoring function of robot operation

- Indication of robot move command
- Acquisition of robot status (Input/output signals, Variables, Shift Values)

SUPPORT SYSTEMS

Robot systems

System products

NACHI's system engineering team puts its wealth of experience to work for you, providing system solutions that are easy to use along with high-cost performance.

Peripheral devices for the robot

NACHI provides proven highly-reliable robot application devices.

Offline program system

Robot operations can be simulated before installation to check performance. Creating an operation program beforehand allows the robot to be directly installed in the assembly line.



Post-installation service

From setup through startup

NACHI's skilled technicians provide support during the installation process, from setup to connection, teaching, movement, and supervision, until the line is fully operational.

Quick response to emergency calls

NACHI's specialized technicians are "on-call" to immediately respond to customer emergencies.

Reliable support from remote locations

Robots can be operated remotely when placed online, allowing specialized service professionals to provide accurate support to worldwide locations.

The right parts when you need them

Our service locations always have important maintenance parts in stock. We can deliver the parts you need quickly.

Periodic inspections

As a trusted and reliable partner, NACHI performs periodic inspections to extend the life of your robot.

Overhauls

NACHI provides a selection of services suited to the conditions of your robot and performs overhauls to ensure that your robot is always in the best condition. NACHI can also provide temporary replacement robots to keep your line operating during repairs.



Overhauls

Training

Robot training course

Fully utilize your Nachi robots, we have robot training classes which use our own curriculum to teach the basics of operating and maintaining robots.

We support a wide range of robots from compact MZ series to large robots and offer training classes tailored to your needs. We will flexibly comply to your request, please feel free to contact us.



NR: connect

Software enables to collection of robot operation data and visualizations.

BY connecting robots to NR: connect, it is possible to collect, visualize operational status data* and improve maintainability.

*Real-time data: 23 items such as "each axis angle" and "each axis current"

Condition monitoring data: 56 items such as "cycle time," "life time" and "CPU load"

Data Collector (Robot data collection software) Options

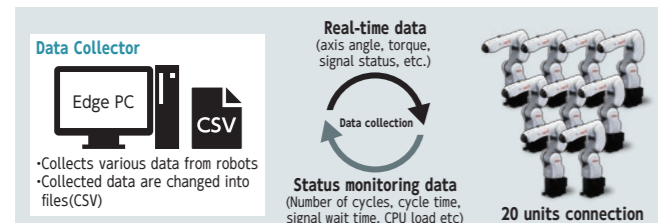

- Constantly monitor the error status of robot controller and automatically save the status when an error occurs
- The output data can be imported to the customer's core system, etc.

Smart Monitor (robot data monitoring software) Options

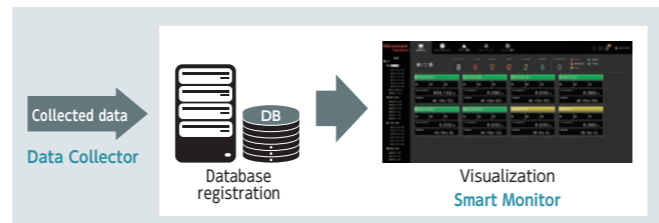

- Display the data collected by Data Collector clearly on a screen
- Intuitive UI gives you easy access to the information you need so that robot operation status can be checked in real-time.
- When an error occurs, the operating status before and after the error is displayed graphically and makes it easy to understand the situation before and after the error.

WORLD SERVICE NETWORK

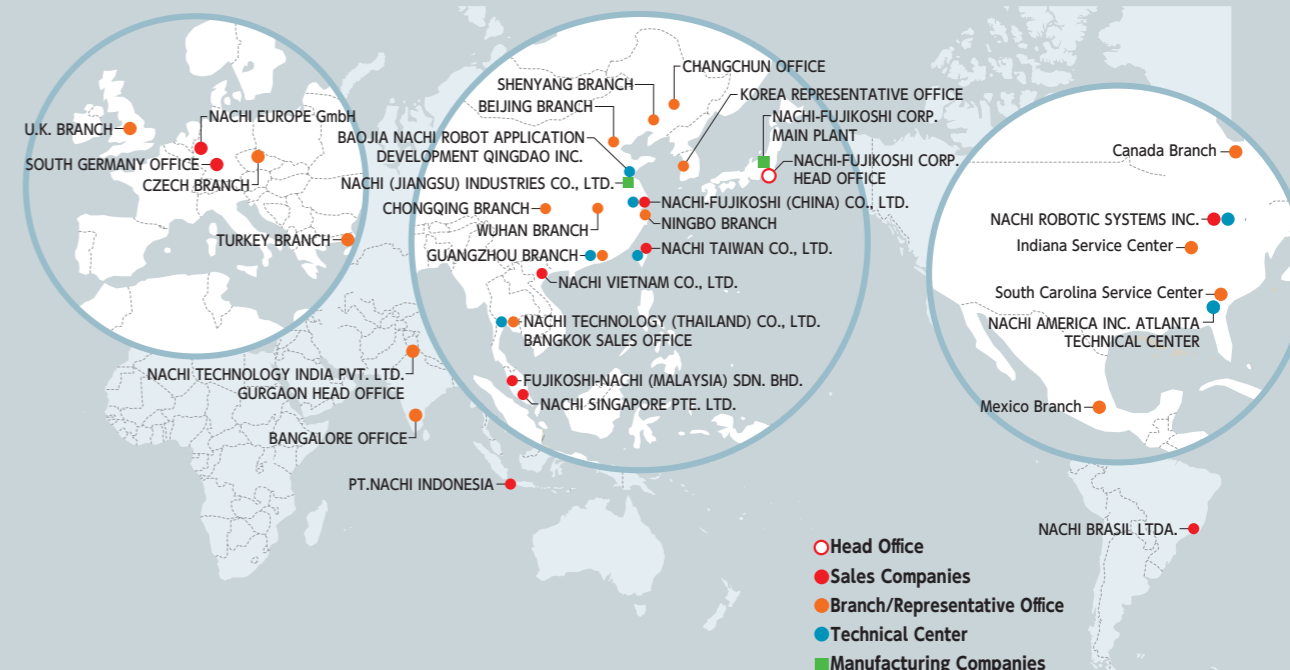

NACHI-FUJIKOSHI CORP. <https://www.nachi-fujikoshi.co.jp>

Head Office

Shiodome Sumitomo Bldg.17F, 1-9-2 Higashi-Shinbashi, Minato-ku, Tokyo 105-0021
Tel: +81-(0)3-5568-5111 Fax: +81-(0)3-5568-5206

Robot division

1-1-1 Fujikoshi-Honmachi, Toyama 930-8511, JAPAN
Tel: +81-(0)76-456-2223 Fax: +81-(0)76-493-5253

Overseas subsidiaries

AMERICA

NACHI ROBOTIC SYSTEMS INC.
46200 W. 12 Mile Rd. Novi, Michigan 48377, U.S.A.
Tel: +1-248-305-6545 Fax: +1-248-305-6542
URL: <http://www.nachirobotics.com/>

Indiana Service Center
715 Pushville Road, Greenwood, Indiana, 46143, U.S.A.
Tel: +1-502-517-1553 Fax: +1-317-535-3659

South Carolina Service Center
1310 Garlington Road, Suite L, Greenville, SC 29615, U.S.A.
Tel: +1-864-458-8000 Fax: +1-864-458-8256

Canada Branch
89 Courtland Ave., Unit No.2, Concord, Ontario, L4K 3T4, CANADA
Tel: +1-905-760-9542 Fax: +1-905-760-9477

Mexico Branch
Av. 100 Metros No.1112-A Nueva Industrial Vallejo Gustavo A. Madero, Ciudad de Mexico C.P. 07700, MEXICO
Tel: +52-55-5312-6556 Fax: +52-55-5312-7248

NACHI AMERICA INC. ATLANTA TECHNICAL CENTER
1950 Evergreen Blvd. Duluth, GA 30096, U.S.A.
Tel: +1-877-622-4487
URL: <http://www.nachiamerica.com/>

NACHI BRASIL LTDA. SAO PAULO BRANCH
Av. Paulista, 453, Primeiro Andar, Conj. 11, 12, 13 e 14, Cerqueira Cesar, São Paulo-SP, CEP : 01311-000, BRASIL
Tel: +55-11-3284-9844 Fax: +55-11-3284-1751
URL: <https://www.nachi.com.br/>

EUROPE

NACHI EUROPE GmbH
Bischofstrasse 99, 47809, Krefeld, GERMANY
Tel: +49-(0)2151-65046-0 Fax: +49-(0)2151-65046-90
URL: <http://www.nachi.de/>

SOUTH GERMANY OFFICE
Pleidelsheimer Str.47, 74321, Bietigheim-Bissingen, GERMANY
Tel: +49-(0)7142-77418-0 Fax: +49-(0)7142-77418-20

U.K. BRANCH
Unit 3, 92, Kettles Wood Drive, Woodgate Business Park BIRMINGHAM B32 3DB, U.K.
Tel: +44-(0)121-423-5000 Fax: +44-(0)121-421-7520

CZECH BRANCH
Obchodni 132, Cestlice 251 01, Czech Republic
Tel: +420-(0)255-734-000 Fax: +420-(0)255-734-001

TURKEY BRANCH
Ataturk Mah. Mustafa Kemal Cad. No: 10/1A. 34758 Atasehir / Istanbul, TURKEY
Tel: +90-(0)216-688-4457 Fax: +90-(0)216-688-4458

ASIA

不二越 (中国) 有限公司
NACHI-FUJIKOSHI (CHINA) CO., LTD.
5F, Building A, National Center for Exhibition and Convention, 1988 Zhuguang Road, Qingpu District, Shanghai, 201702, CHINA
Tel: +86-(0)21-6915-2200 Fax: +86-(0)21-6915-5427

NACHI TECHNOLOGY (THAILAND) CO., LTD. BANGKOK SALES OFFICE
Unit 23/109(A), FL24th Sorachai Bldg., Sukhumvit 63 Road(Ekamai), Klongtonnuu, Wattana, Bangkok 10110, THAILAND
Tel: +66-2-714-0008 Fax: +66-2-714-0740

ROBOT TECHNICAL CENTER
170/2 (1st floor) Ocean Tower 1 Soi Sukhumvit 16, Ratchadaphisek Rd., Klongtoey, Klongtoey, Bangkok 10110, THAILAND
Tel: +66-2-250-4101 Fax: +66-2-258-4103

NACHI SINGAPORE PTE. LTD.
No.2 Joo Koon Way, Jurong Town, Singapore 628943, SINGAPORE
Tel: +65-65587393 Fax: +65-65587371

NACHI VIETNAM CO., LTD.
1502B, 15floor, Lot A1 Indochina Plaza Hanoi, 241 Xuan Thuy Street, Dich Vong Hau ward, Cau Giay dist, Ha Noi city, VIETNAM
Tel: +84-24-3767-8605 Fax: +84-24-3767-8604

FUJIKOSHI-NACHI (MALAYSIA) SDN. BHD.
No.17, Jalan USJ 21/3, 47630 UEP Subang Jaya, Selangor Darul Ehsan, MALAYSIA
Tel: +60-(0)3-80247900 Fax: +60-(0)3-80235884

PT.NACHI INDONESIA
Tempo Scan Tower, 31st Floor J.L.H.R Rasuna Said Kav. 3-4, Kuningan, Jakarta 12950, INDONESIA
Tel: +62-021-527-2841 Fax: +62-021-527-3029

NACHI TECHNOLOGY INDIA PVT. LTD. GURGAON HEAD OFFICE
Unit No. 108, 1st Floor, Sewa Corporate Park, MG Road, Gurgaon-122002, Haryana, INDIA
Tel: +91-124-4502900 Fax: +91-124-4502910

BANGALORE OFFICE
Urban Vault - Citrine No.43/4, 2nd floor, New Airport Road, NH7, Outer Ring Road, Sahakar Nagar, Bangalore 560092, Karnataka, INDIA
Tel: +91-9001848490

台灣那智不二越股份有限公司
NACHI TAIWAN CO.,LTD.
2F, No 23, Lane 15, Sec. 6, Minquan E. Rd., Neihu Dist., Taipei City, TAIWAN
Tel: +886-(0)2-27921895

NACHI-FUJIKOSHI CORP. KOREA REPRESENTATIVE OFFICE
8F, Chan & Chan Tower, 77-9, Samsong-dong, Gangnam-gu, Seoul, 06087, KOREA
Tel: +82-(0)2-6929-2292 Fax: +82-(0)2-6929-2293